

<b>Product Certificate Number</b>	<b>20618-1-CER</b>
<b>Applicant</b>	ABB Power Grids Belgium n.v. – Power Quality Products Allée Centrale, 10 – Z.I. Jumet B-6040 Charleroi, Belgium
<b>Series</b>	PQstorl Series
<b>Models/</b>	PQstorl-M PQstorl-WM PQstorl-C
<b>Type of generating unit</b>	Battery Energy Storage Inverter
<b>Technical Data</b>	See page 2
<b>Software version</b>	µP: v1.0 – Rev10, / DSP v56.1 Rev 34 µP: v1.0 – Rev07, / DSP v56.1 Rev 27 µP: v1.0 – Rev03, / DSP v56.1 Rev 18 and DSP: v56.1 Rev 19
<b>Checksum</b>	7E733AF730F51A874F900C5D5603734B
<b>Software environment</b>	DlgSilent PowerFactory (2020)
<b>Network connection code</b>	<b>VDE-AR-N 4110:</b> 2018-11. Technical requirements for the connection and operation of customer installations to the medium voltage network (TCR medium voltage).

Having assessed the report number:

- Test report: 20618-1-TR performed by CERE (Accredited Laboratory Nº 5314.01) based on the requirements of the EN ISO/IEC 17025: 2017.
- Simulation report 20618-S performed by CERE (Accredited Laboratory Nº 5314.01) based on the requirements of the EN ISO/IEC 17025: 2017.
- Certificate annex with plausibility test 20618-1-CER ANNEX performed by CERE (EA Accredited Entity Nº 147/C-PR335) based on the requirements of the EN ISO/IEC 17065: 2012.

The above-mentioned generating unit complies with the requirements of the:

**VDE-AR-N 4110:2018-11.** Technical requirements for the connection and operation of customer installations to the medium voltage network (TCR medium voltage),

The certification program is:

**TG 8** – Certification of the Electrical Characteristics of Power Generating Units, Systems and Storage Systems as well as for their Components to the Grid. **Rev 9**

**TG 3** – Determination of the Electrical Characteristics of Power Generating Units and systems, Storage Systems as well for their Components in medium-, high- and extra-high voltage grids. **Rev 25.**

**TG 4** – Demands on Modelling and Validating Simulation Models of the Electrical characteristics of Power Generating Units and Systems, Storage Systems as well as for their Components. **Rev 9.**

The certificates include the following information:

- Technical data of the power generating unit, the auxiliary equipment and the software version used;
- schematic structure of the power generating unit;
- summarized information on the properties of the power generating unit.

This certification is according the CERE internal process PET-CERE-09 Rev 27 based on the requirements of the EN ISO/IEC 17065:2012. For this certification process the conformity assessment activities were based on:

- Testing of production samples selected by CERE.
- Audit of quality system according ISO 9001 with certificate number: BE05/051523 issued by a certification body accredited according EN ISO/IEC 17021.
- Inspection of the manufacturing process.

This certificate cancels and supersedes the certificate number 20461-3-CER issued on March 16, 2020

Madrid, August 17, 2020. This certificate is valid until August 17, 2023

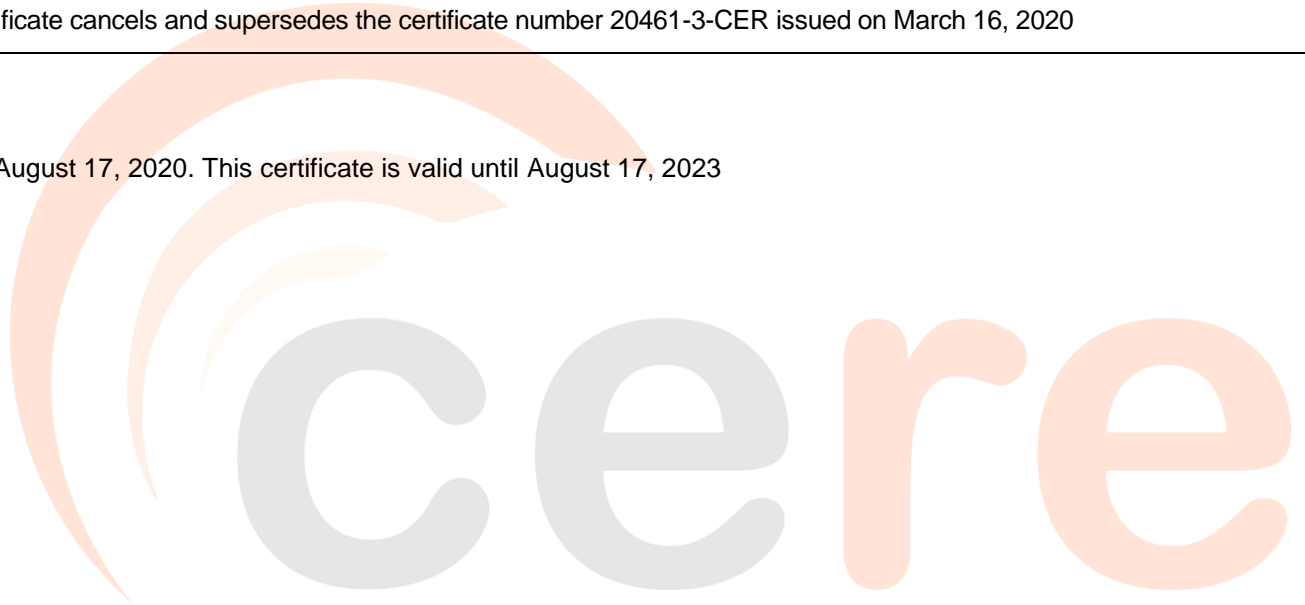

Miguel Martínez Lavin  
Certification Manager

**Technical data**

**PQstorl:**

Specification	PQstorl - M	PQstorl - WM	PQstorl - C
	Module	Wall-mounted	Standalone cabinet
<b>Electrical characteristics</b>			
Connection method	3-wires		
Network voltage (+/-10%)	208 - 415 V		
Network frequency (+/-5%)	50		
Rated power (at 400 V)	30 kW		
Line current rating per base unit (A)	40 A	Full cubicle: 40 A... 600 A	
Inverter technology	Three level inverter		
Modularity	Up to 16 modules can be combined. Different module ratings are allowed		
Equipment losses	<2% of the equipment power typically		
<b>Inverter characteristics</b>			
DC voltage (min)	620 V for 3W application (note 1) Note 1: Limited High voltage ride through support at lower DC voltage		
DC voltage (max)	830 V (890 V with reduced power)		
Response time	<1 network cycle		
<b>Programming/ communication</b>			
Wi-Fi communication	Webserver on smatphone or computer for simple diagnostics and parameters setup		
USB	With dedicated opcional software (servicing / programaming)		
HMI	7-inch color TFT screen (800 x 480 pixels) 198 x 141 x 40 mm IP65 front side / IP20 backside CAN 2B (internal) - RJ12 Ethernet (Modbus TCP) - RJ45 USB 2.0		
Digital I/O on HMI	2 insulated digital input - +24 V (AC or DC) 6 digital NO output - 250 Vac/ 5A (one common polatity), dry contacts		

Electrical Diagram of PQstorl

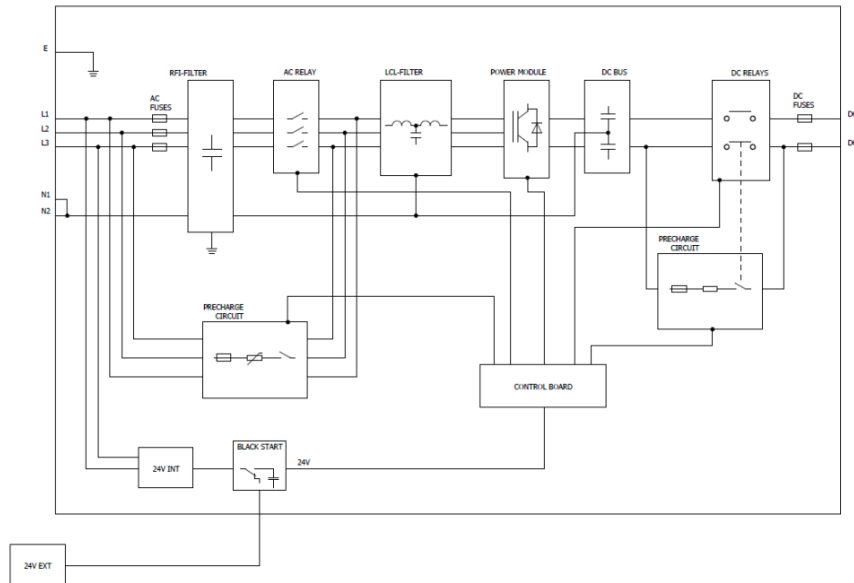

The sample selected to test was representative of the production.  
The sample was selected in:

ABB Power Grids Belgium n.v.  
CC8701-BEPGJ c/o ABB Business Services  
GmbH Kallstadter Str. 1 / 68129 Mannheim,  
Germany.

Sample Report Number:

20461-TM

The inspection of manufacturing process was performed in:  
On MONTH DAY, YEAR

s.a ABB Power Grids Belgium n.v. – Power  
Quality Products  
Allée Centrale 10 – Z.I. Jumet.  
6040, Charleroi, Hainut, Belgium

Inspection Report Number:

20303-19-1-IF

## RECORD OF CHANGES

Revision	Modification / Changes	Date
0	Initial version / Update certificate 20461-3-CER	17/08/2020



## INDEX

<b>1</b>	<b>TECHNICAL SPECIFICATION .....</b>	<b>2</b>
1.1	DEVICE DESCRIPTION .....	2
1.2	TECHNICAL DATA.....	9
1.3	SIMULATION MODEL GENERAL DESCRIPTION ACCORDING TO MANUFACTURER .....	10
<b>2</b>	<b>VDE-AR-N 4110 FORMS .....</b>	<b>13</b>
<b>3</b>	<b>UNIT CERTIFICATE REQUIREMENTS.....</b>	<b>14</b>
3.1	VERIFICATIONS FOR VDE-AR-N 4110 .....	14
3.2	VERIFICATIONS FOR FGW TR8 .....	15
3.3	VERIFICATIONS FOR FGW TR8 TO GIVE COMPLIANCE WITH VDE-AR-N 4110 .....	16
<b>4</b>	<b>PARAMETER LIST .....</b>	<b>37</b>
<b>5</b>	<b>TEST REPORT 43</b>	
5.1	TEST RESULTS.....	43
5.1.1	<i>Rated data (tested units) .....</i>	<i>43</i>
5.1.2	<i>Power quality (switching operations, harmonics, interharmonics, higher frequency components, flickers) .....</i>	<i>44</i>
5.1.3	<i>Active power vs frequency .....</i>	<i>52</i>
5.1.4	<i>Provision of reactive power.....</i>	<i>53</i>
5.1.5	<i>Cut-in conditions .....</i>	<i>54</i>
5.1.6	<i>Disconnection from the grid.....</i>	<i>54</i>
5.1.7	<i>Operation field .....</i>	<i>55</i>
5.1.8	<i>P-Q and S-U Diagrams of the models.....</i>	<i>55</i>

## 1 TECHNICAL SPECIFICATION

### 1.1 DEVICE DESCRIPTION

The PQstorl is a product of the Advanced Inverter Platform (AIP) range. Its external connection terminals and signalling features are listed in Table 1 and depicted in Figures 1 and 2. Figure 3 depicts the internal components of this product.

#### Structure of the device

Figure 1: Back connections

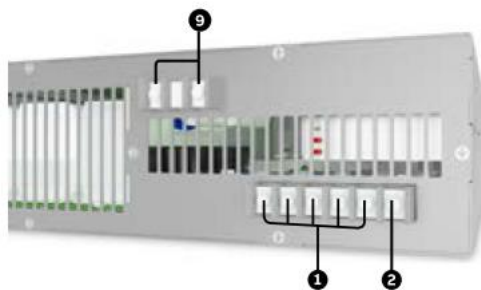

Figure 2: Front connections

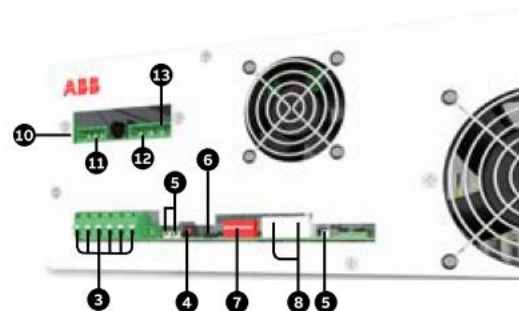

Table 1: External connection terminals and signals on PQstorl

Item	Component	Manual section
1	AC power supply terminal (mandatory)	Section 4.5.2
2	Main earth connection point (mandatory)	Section 4.5.1
3	CT connection terminal (optional)	Section 4.5.5
4	Manual button (start/ stop/ acknowledge fault)	Section 2.5
5	System LEDs	Section 2.4
6	Micro-USB connection for firmware update and troubleshooting	n/a
7	DIP switch to set the address of modules operated in parallel	Section 4.6.1
8	RJ12 terminal for CAN communication between modules operated in parallel and to connect an HMI	Section 4.6
9	DC power supply terminal (mandatory)	Section 4.5.3
10	Black start board (mandatory for black start and islanding)	Section 4.5.4
11	24 V input for black start (mandatory for black start)	Section 4.5.4
12	Voltage input from islanding contactor (mandatory for islanding)	Section 4.5.4
13	Islanding contactor control (mandatory for islanding)	Section 4.5.4

**Electrical functions**

**8 PROTECTIONS**

The PQStorI includes the functionality for the various protection requirements under VDE-AR-N 4105/4110 but as of the time of this publication, these have not been enabled as these functions are presently being satisfied by the centralized NS-protection relay. Nevertheless, their implementation and setup are described below.

Protection are defined in terms of must-disconnect curves. An example is given in Figure 11. The curve is defined using point-arrays. Notice that for these functions the segments between the points are not interpolated. Therefore, only every other point needs to be defined. For the curves controlling the lower limit only the upper left corner points are defined. For the curves controlling the upper limit only the lower left corner points are defined.

It should also be noted that there is a conflict between the FRT curves and the Must disconnect. This is due to the fact that these would typically be based on two different measurement locations.

Note: The order of the points in the point-arrays are of importance. The points must be arranged in the order from less severe to most severe violations. In other words, for the upper limit the points must be arranged in the order of ascending x-values. The lower limit the points must be arranged in the order of descending x-values.

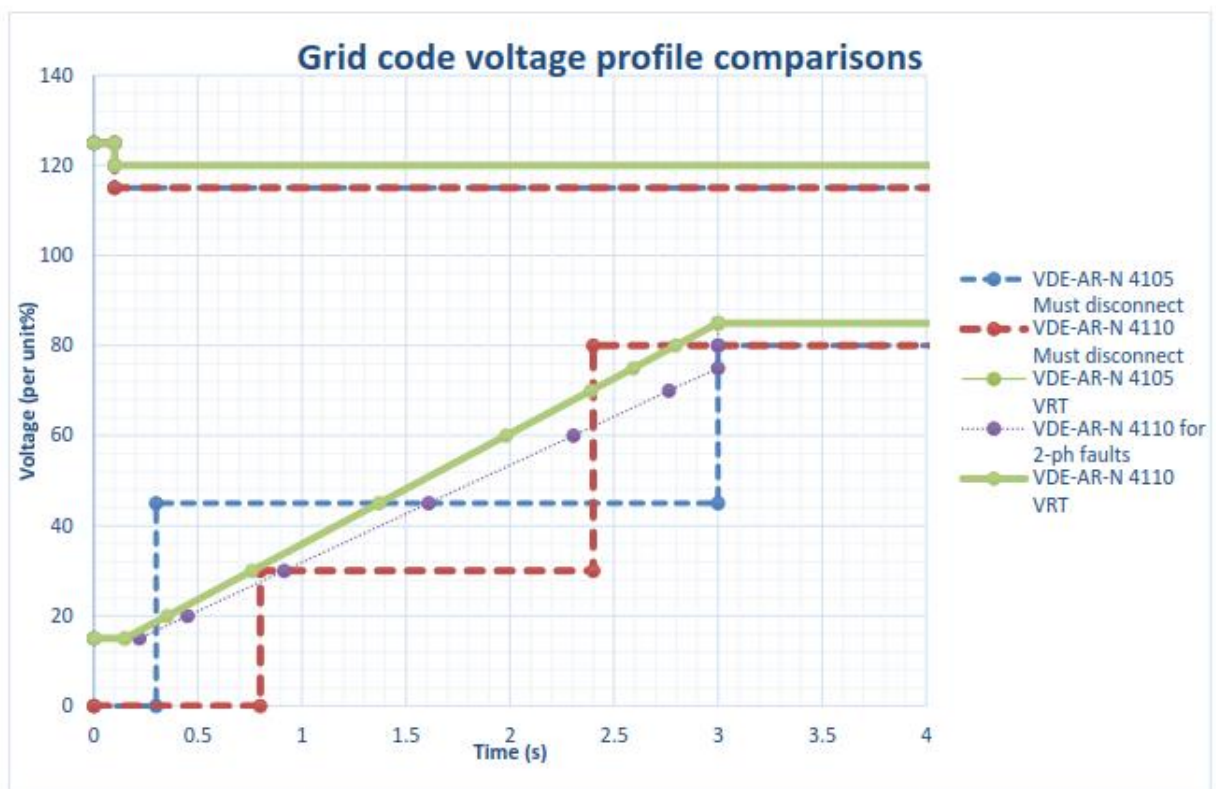

**Figure 11 – Example of must-disconnect curves**

## 8.1 AC Over Voltage

The parameters for this function are listed in Table 9.

**Table 9 – Parameters for AC over-voltage protection**

Parameter	Description	Settings	Default
HVRTD_ModEna	Enables/disables the function	0 or 1	0
HVRTD_NumPts	Number of points in the array	1 to 20	0
HVRTD_sP0_x	Point 0, voltage value	Vmax to 1.3	0
HVRTD_sP0_T	Point 0, time value	0.001 to 3600	0
[...]	[...]	[...]	[...]
HVRTD_sP19_T	Point 19, voltage value	Vmax to 1.3	0
HVRTD_sP19_x	Point 19, time value	0.001 to 3600	0

## 8.2 AC Under Voltage

The parameters for this function are listed in Table 10

**Table 10 – Parameters for AC under-voltage protection**

Parameter	Description	Settings	Default
LVRTD_ModEna	Enables/disables the function	0 or 1	0
LVRTD_NumPts	Number of points in the array	1 to 20	0
LVRTD_sP0_x	Point 0, voltage value	0 to 600	0
LVRTD_sP0_T	Point 0, time value	0.001 to 3600	0
[...]	[...]	[...]	[...]
LVRTD_sP19_T	Point 19, voltage value	0 to 600	0
LVRTD_sP19_x	Point 19, time value	0.001 to 3600	0

## 8.3 Over Frequency

The parameters for this function are listed in Table 11

**Table 11 – Parameters for AC over-frequency protection**

Parameter	Description	Settings	Default
HFRTD_ModEna	Enables/disables the function	0 or 1	1
HFRTD_NumPts	Number of points in the array	1 to 20	0
HFRTD_sP0_x	Point 0, Frequency value	Fnom to Fmax	0
HFRTD_sP0_T	Point 0, time value	0.001 to 3600	0
[...]	[...]	[...]	[...]
HFRTD_sP19_T	Point 19, Frequency value	Fnom to Fmax	0
HFRTD_sP19_x	Point 19, time value	0.001 to 3600	0

## 8.4 Under Frequency

The parameters for this function are listed in Table 12

**Table 12 – Parameters for AC under-frequency protection**

Parameter	Description	Settings	Default
LFRTD_ModEna	Enables/disables the function	0 or 1	1
LFRTD_NumPts	Number of points in the array	1 to 20	0
LFRTD_sP0_x	Point 0, Frequency value	Fmin to Fnom	0
LFRTD_sP0_T	Point 0, time value	0.001 to 3600	0
[...]	[...]	[...]	[...]
LFRTD_sP19_T	Point 19, Frequency value	Fmin to Fnom	0
LFRTD_sP19_x	Point 19, time value	0.001 to 3600	0

## 8.5 Reconnection

At the time of the publication of this document, the PQStorI did not include any grid code reconnection functionality. This will be satisfied using a centralized NS-protection relay. As such all the voltage and frequency protection requirements will also be satisfied by this device.

The set frequency limits are defined by the frequency protection parameters under LFRTD and HFRTD. These are described in Table 11 and Table 12 respectively. Whenever grid frequency shifts below the lowest sLFRTD\_sP\_x or above highest sHFRTD\_sP\_x frequency limits, the PQStorI disconnects within associated time of sLFRTD\_sP\_T and sHFRTD\_sP\_T respectively.

Anti-islanding is enabled/disabled by flag iAI\_ModEna as below:

Parameter	Description	Settings	Default
iAI_ModEna	Enables/ disables Anti Islanding	0 or 1	1

## 8.6 Anti-Islanding

The objective of anti-Islanding protection is to ensure the prevention of any unintentional islanding. Unintentional islanding comes with severe adverse consequences to maintenance personnel as well as equipment connected to the grid.

The method used for the PQStorI module is active frequency drift with positive feedback. In the case of a grid disconnection, the supply frequency is shifted by the control algorithm towards the extreme upper or lower frequency limits depending on the load resonance frequency. When shift in frequency reaches set frequency limits it disconnects the PQStorI from the grid. This process (from the opening of the main grid connection breaker/contactors to stopping of the PQStorI) is accomplished within the 2s maximum limit defined by the grid codes.

The set frequency limits are defined by the frequency protection parameters under LFRTD and HFRTD. These are described in Table 11 and Table 12 respectively. Whenever grid frequency shifts below the lowest sLFRTD\_sP\_x or above highest sHFRTD\_sP\_x frequency limits, the PQStorI disconnects within associated time of sLFRTD\_sP\_T and sHFRTD\_sP\_T respectively.

Anti-islanding is enabled/disabled by flag iAI\_ModEna as below:

Parameter	Description	Settings	Default
iAI_ModEna	Enables/ disables Anti Islanding	0 or 1	1



**Device protection functions**

**1.1.2 Hardware**

In order to meet the protection requirements described in VDE-AR-N 4105 and 4110, the PQStor1 is required to be used in conjunction with a suitably recognized NS-Protection relay. Two examples that can be used are:

ABB - CM-UFD.M33

ZIEHL - UFR1001E

An example wiring diagram showing the interconnection between these is shown in Figure 1.

When the NS-Protection trips or detects a fault with the main disconnection device, it provides a fail-safe (active low) signal to the PQStor1 to trip. Due to the fact that the PQStor1 does not include reconnection functionality, it would typically be setup with automatic reconnection. This means it will reconnect when the NS-protection signal is returned to a high state.

The block diagram of the PQStor1 is shown in Figure 2 which also shows what is described as a "black-start" circuit that enables the inverter to ride through low voltage interruptions while still providing energy for the control circuit.

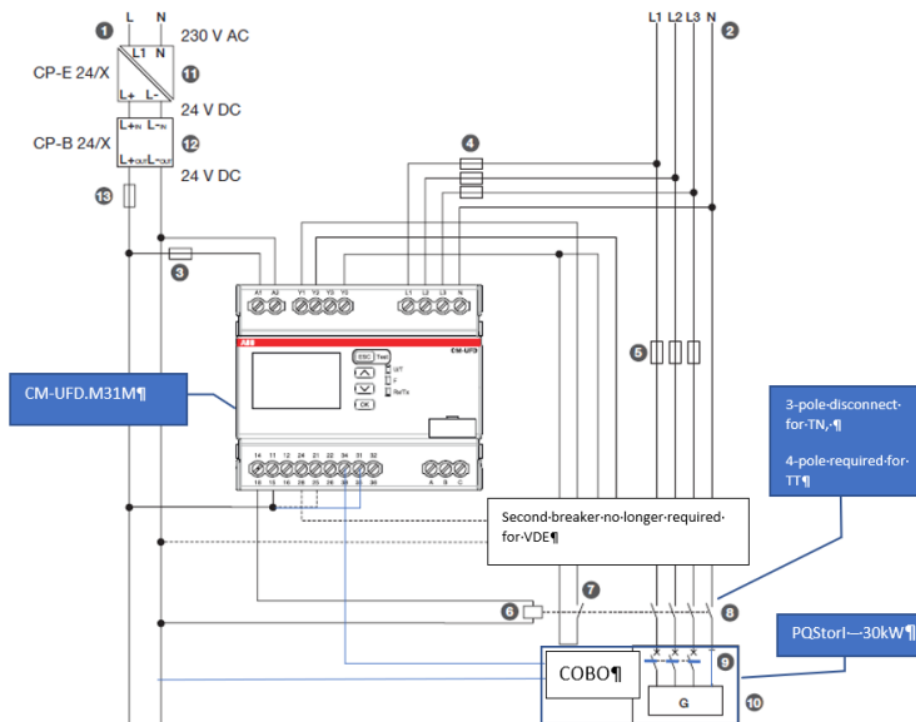

**Figure 1 – Example NS-Protection relay interconnection diagram**

## Interfaces

You can configure the interfaces and the webserver in the Settings menu. The device has the following interfaces for communication and remote monitoring:

### Connecting to the Wi-Fi user interface

Sign in to the Wi-Fi network emitted by the PQstorl using a Wi Fi enabled device such as a computer, a tablet or a smart phone:

SSID: ABB-AIP-DEVICE [DEVICE IP ADDRESS]

Default password: AIPPASS123

Once connected to the Wi-Fi network, open an internet browser on your device and navigate to:  
<http://192.168.3.1/>

### Navigating the Wi-Fi user interface

Figure 5 shows the Wi-Fi user interface. Each page displays the status button of the system (1-in Figure 5 - see Section 3.3), gray navigation buttons for monitoring and operating the system, (2- in Figure 5), and a table summarizing the data called by the gray navigation buttons (3- in Figure 5).

Figure 5: Navigating the Wi-Fi user interface



To enter commands through the Wi-Fi user interface, click the 'Edit' button at the bottom of a settings page (4- in Figure 5), input your changes in the Value column of the settings table (5- in Figure 6) and click the 'Save' button (6- in Figure 6).

Figure 6: Entering commands through the Wi-Fi user interface



**WARNING:** The Wi-Fi user interface will not ask for confirmation. When you click 'Save', it will immediately send the command to the Module. Beware that inappropriate settings could hinder optimal management of the network.

## 1.2 TECHNICAL DATA

Specifications	PQstorl - M	PQstorl - WM	PQstorl - C
	Module	Wall-mounted	Standalone cabinet
<b>Electrical characteristics</b>			
Connection method	3-wire		
Network voltage (+/- 10%)	208 - 415 V		
Network frequency (+/- 5%)	50		
Rated power (at 400 V)	30 kW		
Line current rating per base unit (A)	40 A	Full cubicle: 40 A .. 600 A	
Inverter technology	Three level inverter		
Switching frequency of semiconductors	18 kHz		
Modularity	Up to 16 modules can be combined. Different module ratings are allowed		
Redundancy	Any unit can become a master (defined as the lowest ID that is operational). In case of failure, other unit takes the lead as master		
Equipment losses	<2% of the equipment power typically		
<b>Inverter characteristics</b>			
DC voltage (min)	620 V for 3 W application (note 1) Note 1: Limited High voltage ride through support at lower DC voltages		
DC voltage (max)	830 V (890 V with reduced power)		
Response time	<1 network cycle		
<b>Programming/ communication</b>			
Wi-Fi communication	Webserver on smartphone or computer for simple diagnostics and parameters setup		
USB	With dedicated optional software (servicing/ programming)		
HMI	7-inch color TFT screen (800 x 480 pixels) 198 x 141 x 40 mm IP65 front side / IP 20 backside CAN 2B (internal) – RJ12 Ethernet (Modbus TCP) – RJ45 USB 2.0		
Digital I/O on HMI	2 insulated digital inputs - +24 V (AC or DC) 6 digital NO outputs – 250 Vac/ 5 A (one common polarity), dry contacts		

### **1.3 SIMULATION MODEL GENERAL DESCRIPTION ACCORDING TO MANUFACTURER**

Data included in the ABB document: PQstorl EMT model in DIgSILENT– user manual (PQstorl\_EMT\_PWFv4.3.0), Revision: 4.3.0 of 72 pages.

This is dedicated to PQstorl BESS model in DIgSILENT, with simple grid included. It takes into account ideal grid operation, with inclusion of 0.4/20 kV MV transformer, PoC (point of connection) with 20 kV grid. Complete list of current key functionalities and known limitations are listed in below subchapters, and are described in details in further part of this technical report.

#### **Remarks**

- Model includes LCL filter inside DLL, which consumes up to 3% of reactive power which is visible as constant offset comparing to the reactive power reference set by user. Since version 3.2.1 – reactive power offset compensation was added. Since version 4.3.0 the apparent power dependent compensation formula was also implemented.
- Parameter P\_fPrampAltMax responsible for active power user reference is set to higher value in order to speed up simulation performance.

#### **Limitations**

- Timestep (dt) is fixed to 111,1111  $\mu$ s for EMT model.
- P user reference signal has to be applied with step change from 0 to desired P level after at least one simulation time step.
- Q control dependent on Q user reference signal is limited – due to active power priority in default settings and due to Smax limitation.

#### **Software requirements**

- DIgSILENT PowerFactory 2019 SP3 – 64 bit version with EMT simulation module.
- It is very important to remember that 32-bit DLL files are supported only by the 32-bit PF SW while 64-bit DLL files are supported by the 64-bit PF - [1].

## Deliverables

The attached simulation package PQstorl\_EMT\_PWFv4.3.0.zip includes:

- PowerFactory files:
  - Exemplary project with test network for single units, and exemplary grid with 10 in-  
stanced for multi-instancing feature.
  - PQstorl model template file.
- DLLs:
  - Set of two 64bit DLL files for EMT root model.
- Documentation:
  - PQstorl EMT model in DigSILENT User manual (PQstorl\_EMT\_PWFv4.3.0).

## PQstorl MODEL IMPLEMENTATION

The PQstorl BESS inverter model is provided as DLL file aip\_empt\_win64.dll which was generated in accordance with the ABB framework from the root ML/SL model. The DLL with name aip\_empt\_win64.dll represents EMT simulation model. To connect the DLL models with the PowerFactory simulation Software another intermediate DLL is required digexfun\_aip\_empt\_v430\_64bit.dll. The digexfun DLL files act as a middle layer, that calls the functions of the ABB library and makes the results available to PWF simulation SW [1] - Figure 1.

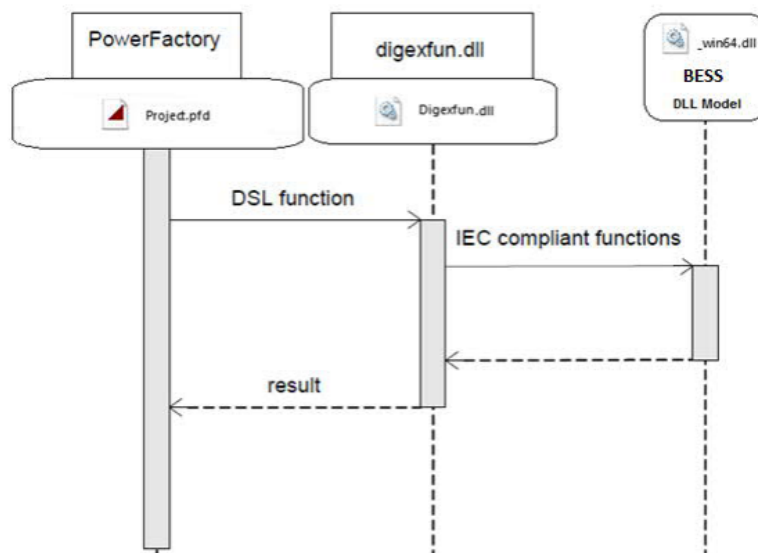

Figure 1. Diagram of the interface between BESS DLL model and PWF simulation model.

The PQstorl DLL model is defined as the block Blk\_BESS\_DLL.BlkDef with 5 inputs and 7 outputs which is represented by the slot Slot\_BESS\_DLL.BlkSlot - Figure 2.

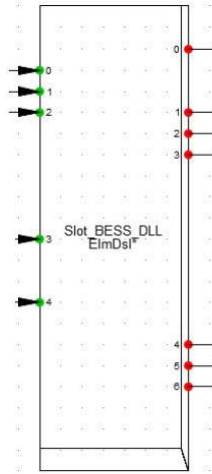

Figure 2. BESS DLL model implementation in PWF environment.

Connection to DLL file is realized by using the special written DSL functions. Inside the Blk\_BESS\_DLL.BlkDef block in the Equation tab the DSL program is written which initialized the inputs and outputs of PQstorl model and updates them during simulation. The BESS\_DLL.ElmDsl common model is integrated in the Composite Frame. The composite frame is used to describe the interconnections between created slots (blocks). Some of the BESS\_FRAME slots represent the DSL common models but some is created to enable connection with the measurement elements as voltage transformer, voltage measurement, PQ measurement and phase measurement device or electric network elements like Static generator and circuit breaker - Figure 3

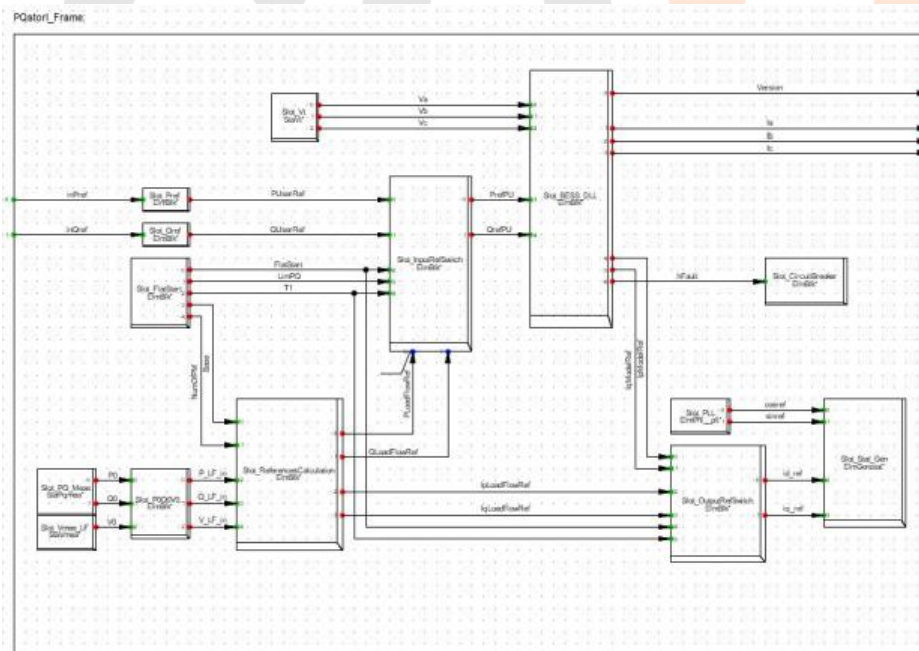



Figure 3. BESS Model - Composite Frame diagram.

## 2 VDE-AR-N 4110 FORMS

Certification Entity for Renewable Energies, S.L. ----- Accredited in accordance with DIN EN ISO/IEC 17065 for VDE-AR-N 4110		
<b>UNIT CERTIFICATE</b>		
Manufacturer	ABB Power Grids Belgium N.V	
Power generating unit type	PQstorl-M / PQstorl-WM / PQstorl-C	
Technical data	Rated active power	See page 3 and 4 of certificate
	Rated voltage	See page 3 and 4 of certificate
	Nominal frequency	See page 3 and 4 of certificate
	Minimum required short-circuit power (for type 1 PGU only)	--
VDE application guide and standards/guidelines which are also applicable	VDE-AR-N 4110: 2018-11 "TCR Medium voltage" FGW TR 8 (Rev. 9), FGW TR3 and TR4 (Rev. 25 and Rev. 9)	
The power generating unit mentioned above meets the requirements of VDE-AR-N 4110: 2018-11 "TCR Medium voltage" The following restrictions and deviations apply: <input checked="" type="checkbox"/> none <input type="checkbox"/> _____ The manufacturer has provided proof of certification of the quality management system of his production facility in accordance with ISO 9001 or subject to production monitoring.		
The certification includes the following: <ul style="list-style-type: none"> <li>- Technical data of the power generating unit, the auxiliary equipment used and the software version used;</li> <li>- Schematic structure of the power generating unit;</li> <li>- Summarized information on the properties of the power generating unit.</li> </ul>		
The certificate is comprised of 5 pages and an Annex of 55 pages. This certificate is valid until 17.08.2023		
Madrid, 17.08.2020 Miguel Martínez, Certification Manager This certificate shall not be used in parts Certification Entity for Renewable Energies, S.L. c/ Valgrande 18, nave H. 28108. Alcobendas. Madrid. Spain		

### 3 UNIT CERTIFICATE REQUIREMENTS

#### 3.1 VERIFICATIONS FOR VDE-AR-N 4110

VDE-AR-N 4110/4120 Clause	Requirement	Statement
11.2.2	System perturbations	COMPLIANT
11.2.3	Quasi static operation and phase swinging	COMPLIANT
11.2.5	Dynamic network stability	COMPLIANT
11.2.6	Validated simulation model	COMPLIANT
11.2.7	Active power output and network security management	COMPLIANT
11.2.8	Active power adjustment as a function of the mains frequency	COMPLIANT
11.2.10	Protection technology and protection settings	NOT APPLICABLE
11.2	Performed by an accredited entity	COMPLIANT

SIMULATION (Further information can be found in 20628-S and 20618-1-CER ANNEX):

Requirement	Statement
Fault Ride Through	COMPLIANT
PQ diagram	COMPLIANT
Frequency and Voltage Abnormal Conditions	NOT APPLICABLE
Active power peaks	COMPLIANT
Plausibility simulations	COMPLIANT

### **3.2 VERIFICATIONS FOR FGW TR8**

Evaluation according to Clause 2.4 of FGW TR8 is not applicable due to this certificate verifies compliance with VDE-AR-N 4110:2018-11 and VDE-AR-N 4120:2018-11. Annex A is evaluated instead in Clause 3.3 of this certificate.



### 3.3 VERIFICATIONS FOR FGW TR8 TO GIVE COMPLIANCE WITH VDE-AR-N 4110

Evaluation according to Annex A, Clause A.1.2. Assessment scope for VDE-AR-N 4110

A.1.2.1. Physical part				Results
A.1.2.1.1.1 PGU. Not applicable				
A.1.2.2 Operating range				
Requirement	Verification	Associated documents	Requirements	
10.2.1.2	11.2.3.1 11.2.4 (for exemplary measurements) 11.2.5.3 (Type 1) 11.2.5.4. (Type 2)	TG 3	Manufacturer's declaration, test report	Compliant
Remaks	Quasi-steady-state operation is defined by a voltage gradient of <math>< 5\%U_n/\text{min}</math> and a frequency gradient of <math>< 0.5\% f_n/\text{min}</math> Carrying the measurement results over to 11.2.1 is permitted.			
No	Evaluation criteria		Acceptance criteria	
1	Quasi-steady-state operation in the frequency and voltage range according to Figure 4 is possible		True	Compliant
1.1	Details of the capability of the PGU as a voltage-time characteristic curve		Details provided	Compliant
1.2.	Verification of the manufacturer's information for quasi-steady-state voltage range based on example measurements completed in accordance with 11.2.4		Details provided	Compliant
11.3	The requirement for operation $\geq 60$ seconds between 85% $U_n$ and 90% $U_n$ as well as 110% $U_n$ and 115% $U_n$ is met		Measurement according to 11.2.5 carried out successfully	Compliant
2	The PGU is suitable for operation in the PGS in accordance with 10.2.1.2.		Details provided	Compliant
For PV-PGU <math>< 100\text{ kW}</math> the following applies:				
1.2	Verification of the manufacturer's information for quasi-steady-state frequency and voltage range based on example measurements completed.		Details provided	Compliant
A.1.2.2.2.1 Polar wheel and/or grid oscillation				
Requirement	Verification	Associated documents	Requirements	
10.2.1.3	11.2.3.2 11.2.3.3	-	Manufacturer's declaration	Not applicable
Remarks	For Type 2 PGU no proof of polar wheel oscillations is required.			
The following generally applies:				
No	Evaluation criteria		Acceptance criteria	
1	Grid oscillation: Evidence of the capability of the PGU		True	Not applicable

	for dynamic grid support successfully provided.			
For Type 1 PGU the following applies				
No	Evaluation criteria		Acceptance criteria	
1	The impedance of the machine transformer has to be stated, if available		Details provided	Not applicable
A.1.2.3. System perturbations				
A.1.2.3.1.1 Rapid voltage variations				
Requirement	Verification	Associated documents	Requirements	
5.4.2	11.2.2.1	TG 3	Test report	
Remarks	Voltage regulation during measurement of the switching factor is permitted (reactive power specifications from the grid operator, e.g. Q(U) characteristic).			Compliant
No	Evaluation criteria		Acceptance criteria	
1	The voltage-effective switching factor dependent on the grid impedance phase angle $kU(\psi)$ is identified.		No evaluation; data only shown	Compliant
2	The flicker-effective switching factor dependent on the grid impedance phase angle $kf(\psi)$ is identified.		No evaluation; data only shown	Compliant
3	The frequency of the switching operations is shown.		True	Compliant
A.1.2.3.1.1 Flicker				
Requirement	Verification	Associated documents	Requirements	
5.4.3	11.2.2.2	TG 3	Test report according to TG 3 is available and permits conformity evaluation versus the requirement in question.	Compliant
Remarks	-			
No.	Evaluation criteria		Acceptance criteria	
1	The flicker coefficient depending on grid impedance phase angle $c(\psi)$ identified.		No evaluation; data only shown	Compliant
A.1.2.3.3.1. Harmonics and interharmonics				
Requirement	Verification	Associated documents	Requirements	
5.4.4	11.2.2.3	TG 3	Test report according to TG 3 is available and permits conformity evaluation versus the requirement in question. Manufacturer's declaration	Compliant
Remarks	-			
No.	Evaluation criteria		Acceptance criteria	
1	Details of harmonic currents provided.		No evaluation; data only shown	Compliant
2	Details of interharmonic currents provided.		No evaluation; data only shown	Compliant
3	Details of higher-frequency currents provided		No evaluation; data only shown	Compliant

No.	Further evidence	Acceptance criteria	
A	Statement of levels as a function of active power starting from technical minimum power	True	Compliant
B	Provided the alternative procedure under TG 3 is used, all variables determined are stated	True	Compliant
<b>A.1.2.3.4.1. Commutation notches</b>			
Requirement	Verification	Associated documents	Requirements
5.4.5	11.2.2.4	TG 3	Test report
Remarks	Evidence only for converters with thyristors which use short-circuit current coming from the grid for commutation of the thyristors		Not applicable
No.	Evaluation criteria	Acceptance criteria	
1	The following items are contained in the unit certificate: Sr Str Design power of the converter P Pulse count of converter $\alpha$ Unfavourable control angle of converter	True	Not applicable
2	The items stated above are also shown in the unit certificate in case of relevant commutation drops caused by auxiliary drives	True	Not applicable
3	Commutation drops (to the extent present) are shown in the unit certificate.	True	Not applicable
<b>A.1.2.3.5.1. Asymmetries</b>			
Requirement	Verification	Associated documents	Requirements
5.4.6	11.2.2.5	TG 3	Test report
Remarks	If the limit value is exceeded as part of the unit certification, the 1-minute mean has to be disclosed as a function of apparent power. It is then evaluated within the framework of system certification.		Compliant
No.	Evaluation criteria	Acceptance criteria	
1	Positive and negative phase sequence system of the feed-in current must be provided as a function of the apparent power.	Details provided	Compliant
2	Limit value is not exceeded	Quotient of the currents from positive and negative phase sequence system $\leq$ 1.5%	Compliant
For Type 1 PGU the following applies:			
No.	Evaluation criteria	Acceptance criteria	
1	Feed-in current must be provided as positive and negative phase sequence system as 1-minute mean values for each power bin (from technical minimum power up to 100% of the rated active power).	Details provided	Not applicable

For Type 2 PGU the following applies:				
No.	Evaluation criteria		Acceptance criteria	
1	Positive and negative phase sequence system of the feed-in current must be provided for each 10% power bin (from 10% to 100% PrE) as a function of the apparent power as 1-minute mean values.		Details provided	Compliant
A.1.2.3.6.1. Audio frequency ripple control				
Not applicable				
A.1.2.3.7.1. Carrier frequency use of the customer grid				
Not applicable				
A.1.2.4.1 Reactive power				
Requirement	Verification	Associated documents	Requirements	
10.2.2.1 to 10.2.2.3	11.2.4	TG 3	Test report, manufacturer's declaration	Compliant
Remarks				
-				
No.	Evaluation criteria		Acceptance criteria	
1	Every setpoint value specified by the grid operator can be achieved within the required reactive power range (Figure 5). Note: In case the PGU does not meet the requirement it has to be met at the level of the PGS at the latest.		≤ 4 min	Compliant
2	The types of setpoint value specifications and interfaces for control of the reactive power provision are documented.		Details provided	Compliant
3	Details of the Q-step response via a step response for the interface/setpoint value combinations.		Details provided	Compliant
4	Representation of the reactive power capability as a function of the voltage and feed-in active power as an illustration and in a table. (Data for 0.85 Un – 1.15 Un provided in 5% steps)		True	Compliant
5	PQ characteristic is verified for 'max underexcited', 'max overexcited' and 'Q=0'		True	Compliant
6	Active power reduction may be parametrised to the benefit of reactive power feed-in.		Details provided	Compliant
7	Voltage-independence is verified for at least two conclusive operating points each for underexcited and overexcited operating ranges.		True	Compliant
For Type 1 PGU the following applies:				
No.	Evaluation criteria		Acceptance criteria	
4	Representation of the PQ diagram as a function of the instantaneous feed-in power (not under 50% active power part load range for cogeneration systems)		Details provided	Not applicable
A.1.2.4.2.1 Procedure for reactive power provision				
Requirement	Verification	Associated documents	Requirements	

10.2.2.4	-	TG 3	Manufacturer's declaration, test report	Compliant
Remarks		-		
No.	Evaluation criteria		Acceptance criteria	
1	The type of setpoint value specifications and interfaces for control of the reactive power provision is stated.		Details provided	Compliant
2	In the event the communication with the PGS controller is disturbed, PGU can be operated with a predefined value or process.		Details provided	Compliant
A.1.2.5. Active power				
A.1.2.5.1.1. General information and grid safety management				
Requirement	Verification	Associated documents	Requirements	
10.2.4.1 10.2.4.2	11.2.7	TG 3	Test report, manufacturer's declaration	Compliant
Remarks		If the function for active power gradient regulation is implemented at the PGS controller level, the evaluations 1 to 3 can be waived with a note referring to the PGS controller to be used.		Compliant
No.	Evaluation criteria		Acceptance criteria	
1	Power gradient for increasing and reducing the active power		0.33% PrE/s ≤ gradient ≤ 0.66% PrE/s (in case of setpoint values specified by third parties also more slowly, for power increase however not more slowly than 4% PrE/min.)	Compliant
2	Even progression of power increase/reduction		True	Compliant
3	Interfaces for specifying active power (grid operator, direct seller) implemented separately as well as the concept checked to make sure lowest active power value is accepted (even if specifications overlap in time).		True	Compliant
4	Control deviation at PGU terminals identified.		True and deviation ≤ 5% Pinst	Compliant
5	The maximum active power output is identified as a mean value over 200 ms, 1 minute and 10 minutes.		True	Compliant
6	If active power output is dependent on environmental conditions (temperature, atmospheric pressure), these interrelationships were shown in the form of a manufacturer's declaration.		True	Compliant
7	If the power gradient is implemented at the PGS controller level, the settling time of the PGU due to an active power step from 90% to 10% PrE and from 10% to 90% PrE must be measured.		No evaluation– data only shown	Compliant
For Type 1 PGU the following applies:				

No.	Evaluation criteria	Acceptance criteria	
7	If the power gradient is implemented at the PGS controller level, the settling time of the PGU due to an active power step from 90% to technical minimum power and from technical minimum power to 90% must be measured	No evaluation– data only shown	Not applicable
A.1.2.5.2.1. Active power output as a function of grid frequency			
Requirement	Verification	Associated documents	Requirements
10.2.4.3	11.2.8	TG 3	Test report, manufacturer's declaration.
Compliant			
Remarks -			
No.	Evaluation criteria	Acceptance criteria	
1	PGU and controllable consumer units respond according to the requirement, if the grid frequency is outside of the tolerance band of $\pm 200$ mHz.	True	Compliant
1.1	The frequency measurement meets the requirements with respect to accuracy and sampling.	$ \Delta f  \leq 10$ mHz in the settled condition $ \Delta f  \leq 50$ mHz for fast frequency changes $\Delta t_{\text{Sampl}} \leq 200$ ms for fast frequency changes	Compliant
1.2.1	The active power operating point can be increased in the range between $f_{\text{Start}} <$ to $f_{\text{Stop}} <$ . The upper threshold can be adjusted between 49.5 Hz and 49.8 Hz. If available, standard values must be given.	P(f) increase is possible in the range $49.5 \text{ Hz} \leq f_{\text{Start}} < \leq 49.8 \text{ Hz}$ to $f_{\text{Stop}} < = 47.5 \text{ Hz}$ .	Compliant
1.2.2	The active power operating point can be reduced in the range between $f_{\text{Start}} >$ to $f_{\text{Stop}} <$ . The lower threshold can be adjusted between 50.2 Hz and 50.5 Hz. If available, standard values must be given.	P(f) reduction is possible in the range $50.2 \text{ Hz} \leq f_{\text{Start}} > \leq 50.5 \text{ Hz}$ to $f_{\text{Stop}} > = 51.5 \text{ Hz}$ .	Compliant
1.2.3	The initial time delay TV of the frequency-dependent active power variation is not more than 2 s, otherwise consultation with the grid operator is required.	$TV \leq 2$ s or justification to the grid operator.	Compliant
1.2.4	Conditions for TV and $Tan90\%$ are met.	After $TV + 0,1$ ( $Tan90\% - TV$ ) at least 9% $\Delta P$ are produced; after $Tan90\%$ at least 90% $\Delta P$ are produced.	Compliant
1.3	The statics of the frequency-dependent active power variation is adjustable in the frequency ranges defined under 1b1 and 1b2 between 2% and 12%. Type testing takes place at a static value of 5%. Note: For storage systems a static value s of 2% applies.	$2\% \leq s = \frac{\Delta f}{f^n} \cdot \frac{\Delta P}{P_{\text{ref}}} \leq 12\%$  $s_{\text{Standard}} = 5\%$ (= 40% $P_{\text{ref}}/\text{Hz}$ )	Compliant

1.4	In the frequency ranges between $f_{Start<}$ and $f_{Stop<}$ and/or $f_{Start>}$ and $f_{Stop>}$ (see 1b1 and 1b2) the PGU tracks up and down the characteristic curve with respect to power output.	True	Compliant
1.5	The active power reduction is possible down to the technical minimum power of the PGU	True	Compliant
1.6	Manufacturer's declaration documents: • The PGU can be operated another 5 s without active power increase above $f_{Stop>}$ . • Separation from the grid only takes place for reasons of self-protection.	True	Compliant
1.7	Transition from critical to normal grid conditions only takes place under the stipulated conditions.	Within 10 min after the frequency returns to the range of $50 \text{ Hz} \pm 0.2 \text{ Hz}$ a reduction of active power to $P_{mom}$ may take place with max. 10% $P_{b,Inst}/min$ .	Compliant
2	PGU transit through fast frequency changes (RoCoF) without disconnecting from the grid.	Manufacturer's declaration documents: $\pm 2.00 \text{ Hz/s}$ in rolling 0.5 s window; $\pm 1,50 \text{ Hz/s}$ in rolling 1.0 s window; $\pm 1,25 \text{ Hz/s}$ in rolling 2.0 s window can be transited without disconnection from the grid. Otherwise the framework conditions for fulfilment of the requirement have to be shown in the certificate.	Compliant
2.1	Manufacturer's declaration documents: In the range between 50 Hz and the curve in Figure 17, PGUs do not reduce their active power.	True	Compliant
3	Below 49.5 Hz gas or steam power plants as well as combustion engines do not reduce their maximum active power output by more than the specified value	Max. permissible P-reduction $10\% \cdot P_{b,Inst} \cdot \frac{49,5 \text{ Hz} - f}{1 \text{ Hz}}$ for $f < 49.5 \text{ Hz}$	Not applicable
4	Manufacturer's declaration documents: Combustion engines and gas turbines reduce their active power by a maximum of 3% PrE until returning to above 49.5 Hz in the dynamic short-term range as presented in Figure 17	True	Not applicable
5	Gas turbines or combustion engine PGUs vary their active power output with at least the specified	$\frac{dP}{dt} \geq 66\% P_n/min$ for $P_n \leq 2 \text{ MW}$ ;	Not applicable

	gradient.	$\frac{dP}{dt} \geq 20 \% P_n / \text{min}$ for $P_n > 2 \text{ MW}$	
No.	Additional evidence	Acceptance criterion	
A	Setting ranges for the active power reduction (fStart>, fStop>, fStart<, fStop<, static, “operating on the characteristic”) are stated.	Shown in manufacturer’s declaration.	Compliant
B.1	On the characteristic curve according to Figure 25, the points 1., 2., 3., 4.1 and 5. in the overfrequency range were achieved in the indicated sequence.	True The initial active power feed-in is at least 50% PrE. The steps are held for at least 30 s.	Compliant
B.2	At each of the steps, a pause took place for at least the time required to demonstrate that no undamped power oscillations took place.	True, if decaying resonance behaviour evident.	Compliant
B.3	Rise and settling times have been determined for the steps from 2 to 3 and 3 to 4.1. They meet the specifications.	The rise and settling times determined meet the specifications.	Compliant
B.4	The active power gradient has been determined for the step from 4.1 to 5. This meets the specifications.	The determined active power gradient meets the specifications.	Compliant
C.1	On the characteristic curve according to Figure 25, the points 1., 2., 3.1, 3.1, 4.1., 5. and 6. in the underfrequency range were achieved in the indicated sequence.	True. The initial active power feed-in is a maximum of 10% PrE. The steps are held for at least 30 s.	Compliant
C.2	At each of the steps, a pause took place for at least the time required to demonstrate that no undamped power oscillations took place.	True, if decaying resonance behaviour evident.	Compliant
C.3	Rise and settling times have been determined for the steps from 2 to 3.1 and 3.1 to 4.1. They meet the specifications.	The rise and settling times determined meet the specifications.	Compliant
C.4	The active power gradient has been determined for the step from 5. to 6. This meets the specifications.	The determined active power gradient meets the specifications.	Compliant
D	An operating capability above 51.5 Hz has been shown, if present.	Shown in manufacturer’s declaration.	Compliant
For Type 1 PGU the following applies:			
No.	Evaluation criteria	Acceptance criteria	
1.1.1	PGU, storage systems and controllable consumer units of Type 1 comply with the requirements for rise and settling times according to Table 9 for the active power increase in the ranges 49.8 Hz to 47.5 Hz as well as 51.5 Hz to 50.2 Hz. The exception rule according to Table A.1.2.5.2.1 item 5 for CE or gas turbines should be noted as a priority.	$T_{an90\%} \leq 5 \text{ min}$ for $\Delta P \leq 20 \%$ $P_b, Inst; Tein \leq 6 \text{ min}$	Not applicable
1.1.2	PGU, storage systems and controllable consumer units of Type 1 comply with the requirements for rise and settling	$T_{an90\%} \leq 8 \text{ s}$ for $\Delta P \leq 45 \%$ $P_b, Inst; Tein \leq 30 \text{ s}$	Not applicable

	times according to Table 9 for the active power reduction in the ranges 49.8 Hz to 47.5 Hz as well as 51.5 Hz to 50.2 Hz. The exception rule according to Table A.1.2.5.2.1 item 5 for CE or gas turbines should be noted as a priority.		
4	The frequency steps are maintained for a longer period of time than for other types. (Only valid for CEs and gas turbines)	The steps are held for at least 120 s	Not applicable
<b>No.</b>	<b>Additional evidence</b>	<b>Acceptance criteria</b>	
C.1	On the characteristic curve according to Figure 25, the points 1., 2., 3.1, 3.1, 4.1., 5. and 6. in the underfrequency range were achieved in the indicated sequence.	True. The maximum initial active power fed in corresponds to the technical minimum power.	Not applicable
For Type 2 PGU the following applies:			
<b>No.</b>	<b>Evaluation criteria</b>	<b>Acceptance criteria</b>	
1.1.1	PGU and controllable consumer units of Type 2 comply with the requirements for rise and settling times according to Table 9 for the active power increase in the ranges 49.8 Hz to 47.5 Hz as well as 51.5 Hz to 0.2 Hz. (Limitations due to technical restrictions need to be observed)	$T_{an90\%} \leq 10$ s for $\Delta P \leq 50\% P_{b,Inst}$ ; $T_{ein} \leq 30$ s	Compliant
1.1.2	PGU and controllable consumer units of Type 2 comply with the requirements for rise and settling times according to Table 9 for the active power reduction in the ranges 49.8 Hz to 47.5 Hz as well as 51.5 Hz to 50.2 Hz. (Limitations due to technical restrictions need to be observed)	$T_{an90\%} \leq 2$ s for $\Delta P \leq 50\% P_{b,Inst}$ ; $T_{ein} \leq 20$ s	Compliant
1.1.3	Storage systems of Type 2 comply with the requirements for rise and settling times according to Table 5 for the active power increase in the ranges 49.8 Hz to 47.5 Hz as well as 51.5 Hz to 50.2 Hz	$T_{an90\%} \leq 1$ s for $\Delta P \leq 100\% P_{b,Inst}$ ; $T_{ein} \leq 10$ s	Compliant
1.1.4	Storage systems of Type 2 comply with the requirements for rise and settling times according to Table 5 for the active power reduction in the ranges 49.8 Hz to 47.5 Hz as well as 51.5 Hz to 50.2 Hz.	$T_{an90\%} \leq 1$ s for $\Delta P \leq 100\% P_{b,Inst}$ ; $T_{ein} \leq 10$ s	Compliant
1.1.5	Wind turbines comply with the requirements for rise times for the active power increase in the range 49.8 Hz to 47.5 Hz as well as 51.5 Hz to 50.2 Hz. (Limitations due to technical restrictions need to be observed)	$T_{an90\%} \leq 5$ s for $\Delta P \leq 20\% P_{b,Inst}$ From $P = 50\% P_{b,Inst}$ :	Not applicable
1.3	The standard value of the static behaviour is 2% for Type 2 storage systems.	sStandard=2% (=100% Pref/Hz)	Compliant
6	Feed-in operation at 10% PrE is possible.	True	Compliant
7	The specifications for frequency-dependent active power are met (Figure 17).	True	Compliant

No.	Additional evidence		Acceptance criteria	
B.1 WE	WT: On the characteristic curve according to Figure 25, the points 1., 2., 3., 4.2 and 5. in the overfrequency range were achieved in the indicated sequence.		True. The initial active power feed-in is at least 50% PrE.	Not applicable
B.1 SP	Storage: On the characteristic curve according to Figure 26, the points 1., 2., 3., 4. and 5. in the overfrequency range were achieved in the indicated sequence.		True. The initial active power feed-in is at least 100 % PrE	Compliant
B.3 WE	WT: Rise and settling times have been determined for the steps from 2 to 3 and 3 to 4.2. They meet the specifications.		The rise and settling times determined meet the specifications.	Not applicable
B.3 SP	Storage: Rise and settling times have been determined for the steps from 2 to 3 and 3 to 4. They meet the specifications		The rise and settling times determined meet the specifications.	Compliant
B.4 WE	WT: The active power gradient has been determined for the step from 4.2 to 5. This meets the specifications.		The determined active power gradient meets the specifications	Not applicable
B.4 SP	Storage: The active power gradient has been determined for the step from 4. to 5. This meets the specifications.		The determined active power gradient meets the specifications	Compliant
C.1 WE	WT: On the characteristic curve according to Figure 25, the points 1., 2., 3., 4.2., 5. and 6. in the underfrequency range were achieved in the indicated sequence		True. The initial active power feed-in is a maximum of 60% PrE.	Not applicable
C.1 SP	Storage: On the characteristic curve according to Figure 26, the points 1., 2., 3., 4., 5. and 6. in the underfrequency range were achieved in the indicated sequence.		True. The initial active power feed-in is around 100% PrE.	Compliant
C.3 WE	WT: Rise and settling times have been determined for the steps from 2 to 3 and 4 to 5. They meet the specifications.		The rise and settling times determined meet the specifications	Not applicable
C.3 SP	Storage: Rise and settling times have been determined for the steps from 2 to 3 and 4 to 5. They meet the specifications.		The rise and settling times determined meet the specifications.	Compliant
A.1.2.6 Connection				
A.1.2.6.1.1. Black start capability				
Not applicable				
A.1.2.6.2.1 Switching-in conditions				
Requirement	Verification	Associated documents	Requirements	
10.4	11.2.11	TG 3	Manufacturer's declaration, test report	Compliant
Remarks	It must be shown in the unit certificate whether the procedure is implemented in the PGU or PGS controller.			
No.	Evaluation criteria		Acceptance criteria	
1	In the voltage-frequency range to be shown (47.5 Hz $\pm$ 0.1 Hz and at 50.2 Hz		True	Compliant

	± 0.1 Hz as well as at 90% Un ± 2% Un and 110% ± 2% Un) a connection of the PGU to the medium-voltage grid is technically possible		
2	Automatic connection of the PGU after disconnection from the grid by triggering a grid protection device is only possible in given voltage and frequency ranges.	$U \geq 95\% U_n$ 49.9 Hz $\leq f \leq 50.1$ Hz	Compliant
3	Automatic reconnection only takes place after grid stabilisation time which can be adjusted.	Stabilisation time can be adjusted from 0 to 30 min	Compliant
3.1	The evidence was provided based on a delay time of 5 min and the possible setting range was stated.	True	Compliant
4	The gradient of active power was shown. a) By means of manufacturer's declaration: Setpoint specifications (connection without protection being triggered previously) and b) By means of measurement: Reconnection after voltage loss (connection after grid protection was triggered)	True	Compliant
4.1	The gradients determined under 4 are always larger than 0.33% PrE/s.	True	Compliant
4.2	The gradients determined under 4 are always smaller than 0.66% PrE/s.	True	Compliant
No.	Additional evidence	Acceptance criteria	
A	The gradient was measured after a power outage of at least one minute up to an active power of at least 50% PrE .	True	Compliant
For Type 2 PGU the following applies			
No.	Evaluation criteria	Acceptance criteria	
1*	Asynchronous generators with drive unit are connected within the indicated speed range.	Connection within speed range 95% $n_s \leq n \leq 105\% n_s$	Compliant
1.1*	The connection of the asynchronous generators with drive unit takes place on a current-limited basis.	True. Information provided in the manufacturer declaration regarding the current-limiting measures.	Compliant
2	Asynchronous generators which cannot be connected when de-energised (e.g. DFIG) comply with the general connection conditions.	True. Shown in manufacturer's declaration.	Compliant
<i>*Remark: Only valid for grid-connected asynchronous generators.</i>			
A.1.2.7 FRT			
A.1.2.7.1.1 Loss of static stability			
Requirement	Verification	Associated documents	Requirements
10.2.1.3 10.5.2	11.2.12	-	-
Remarks	No evidence necessary		
A.1.2.7.2.1 Island and partial grid operation capability			
Requirement	Verification	Associated documents	Requirements

10.2.1.4	-	-	Manufacturer's declaration	Compliant
Remarks	<p>No requirements <b>for island operation</b> have been defined.</p> <p><b>Partial grid operation capability</b> does not constitute a minimum requirement. The distribution grid operator may however require partial grid operation capability and the controller stability in individual cases. Only in this case do the following requirements apply.</p> <p>Here only optional characteristics of the PGU are shown, however not a declaration of conformity.</p>			
No.	Evaluation criteria		Acceptance criteria	
1	All requirements of static and dynamic grid support according to chapter 10 of the application rule are met.		True	Compliant
2	Is it possible to regulate out sudden load cut-ins of up to 10% Pb inst (however maximum 50 MW).		True	Compliant
For Type 1 PGU the following applies:				
No.	Evaluation criteria		Acceptance criteria	
1	Power reduction to 55% Pinst is possible.		True	Not applicable
For Type 2 PGU the following applies:				
No.	Evaluation criteria		Acceptance criteria	
1	Power reduction to 10% Pinst is possible.		True	Compliant
A.1.2.7.3.1. Dynamic grid support				
Requirement	Verification	Associated documents	Requirements	
10.2.1.2 10.2.3	11.2.5	TG 3 DIN EN 60034-1 (VDE 0530-1)	Test report, manufacturer's declaration	Compliant
Remarks	Calculation of the short-circuit AC currents is done by the certification body and is identified in the PGU certificate.			
No.	Evaluation criteria		Acceptance criteria	
1	Own protection allows operation between the lower and upper FRT limit curve.		Trials required under 11.2.5 have been successfully completed.	Compliant
2	FRT trials have been successfully carried out with a pre-fault reactive power of $\pm 10\%$ PrE.		True	Compliant
3	An FRT trial was carried out with maximum underexcited and one with maximum overexcited reactive power according to manufacturer information (or with $\cos \varphi \leq 0.5$ over- or underexcited, as long as the capacity of the PGU is higher).		True	Compliant
4	The behaviour of the PGU or the component with rapid voltage changes was proven using a voltage step by at least $10\% U_n$ to a value $> 110\% U_n$ for symmetrical as well as to $\geq 110\% U_n$ as the largest external conductor voltage for asymmetric voltage increases for a period of $\geq 5$ s.		Minimum duration $\geq 5$ s	Compliant

4.1	Starting from 1 January 2021, during the commissioning of the PGS evidence must be provided of the ability to deal with a symmetrical voltage step of at least 15% Un to a value > 115% Un for ≥ 5 s or ≥ 115% Un for ≥ 60 s in addition in the form of a manufacturer's declaration.	True	Not applicable
4.2	This will identify under which assumptions regarding the relevant influencing variables and under which limitations it is possible, or not possible, to master a symmetrical voltage step of at least 15% Un to a value > 115% Un for ≥ 5 s or ≥ 115% Un for ≥ 60 s.	True	Compliant
5	The correct behaviour in transition from dynamic to quasi steady-state operation of the power generating units must be proven for a symmetrical voltage drop for a minimum duration of ≥ 60 s by decreasing the grid voltage to a value between 85% and 90% Un.	True	Compliant
6	The correct behaviour in transition from dynamic to quasi steady-state operation of the power generating units must be proven for a symmetrical voltage increase by increasing the grid voltage to a value ≥ 110 Un for ≥60 s.	True	Compliant
7	The PGU feeds in reactive current in case of a grid fault in accordance with the requirement (see the following tables for Type 1 and/or Type 2).	True	Compliant
8	The PGU is able to ride through multiple faults in accordance with the requirements.	True	Compliant
No.	Additional criteria	Acceptance criteria	
A	The tests according to TG 3 were completed without disconnection from the grid. This also provides evidence of the FRT capability for the auxiliary drives used during the measurement.	True	Compliant
B	A voltage-time characteristic curve (capability of the PGU) is present. Manufacturer information should at least correspond to the required capability from VDE AR N 4110 Figure 12, 13 or 14	Manufacturer specification available. The capability at the PGU terminals may be lower as long as measures are taken within the PGS which meet the requirement for the PGS (e.g. use of a tap changer in the PGU transformer, voltage regulation, etc.). The additional measure and/or components has to be stated on the	Compliant

		cover sheet of the unit certificate.	
For Type 1 PGU the following applies:			
No.	Evaluation criteria	Acceptance criteria	
1	Symmetrical and asymmetric voltage drops when reducing the grid voltage to a value respectively between 70% Un and 80% Un, 45% Un and 60% Un, 30% Un and 35% Un carried out.	Minimum period according to the boundary line from Figure 13	Not applicable
2	The time period from fault clearance to 60 seconds after fault clearance must be investigated with respect to the PGU disconnecting from the grid. Evaluation of active power increase after fault clearance.	PGU does not disconnect from the grid in the period from fault clearance to 60 s after fault clearance.	Not applicable
7	For PGU versions not type-tested according to TG 3 (evidence as part of range formation), the evaluation of transient stability is carried out according to Chapter 11.2.5.3. Parameter variations, where required, are undertaken according to Table H-4 in E.2.5. Simulation of stability at 5 x SrE = SkV was carried out.		Not applicable
No.	Additional evidence	Acceptance criteria	
C	The evidence that a Type 1 power generating unit is able to ride through multiple consecutive voltage drops has been provided once the generator is proven to be designed according to DIN EN 60034-1 (VDE 0530-1), Chapter 9.3.2. Alternatively, the evidence was provided through measurement using the test sequence according to Table 14. Based on a manufacturer's declaration it must be shown comprehensibly that the PGU is capable of riding through a multiple fault again after 30 min.	True	Not applicable
For Type 2 PGU the following applies:			
No.	Evaluation criteria	Acceptance criteria	
<b>Remaining on the grid</b>			
1.1	The PGU does not become unstable and does not separate from the grid as long as all line-line voltages are within the boundary curve shown in figure 14	Trials required under 11.2.5 have been successfully completed.	Compliant
1.2	All UVRT and OVRT tests have been fully completed.	True	Compliant
1.3	The PGUs do not disconnect from the grid during all UVRT tests.	True	Compliant
1.4	The PGUs do not disconnect from the grid during all OVRT tests.	True	Compliant
<b>Feed-in of fault current</b>			
<p><i>Note: It is also permissible to have continuous dynamic grid support in the sense of the following requirements, which is permanently active and active in parallel with steady-state voltage maintenance, independent of fulfilment of the criteria for the fault start and end.</i></p>			

7.1	The rise time of max 30 ms of the additional reactive current in the positive and negative phase sequence system after the start of the fault is provided for each measurement in the measurement report according to TG 3 and meets the requirements.	True	Compliant
7.2	The settling time of max 60 ms of the additional reactive current in the positive and negative phase sequence system after the start of the fault is provided for each measurement in the measurement report according to TG 3 and meets the requirements.	True	Compliant
7.3	For all measurements according to TG 3 where the required k-factor may not be possible to reach due to a current limitation, at least one reactive current to the value of the rated current in each phase must be fed in.	True	Compliant
7.4	The additional reactive current fed into the positive and negative phase sequence system must comply with the limits specified in Annex C.1. (To be proven for voltage deviations with residual voltages $\geq 15\% U_n$ bis $120\% U_n$ ).	The limits in accordance with Annex C.1 have to be complied with for all measurements.	Compliant
7.5	For directly-coupled asynchronous generators: During the complete duration of the fault at a constant drop level the PGU does not draw reactive current from the grid.	True	Not applicable
7.6	For directly-coupled asynchronous generators: The balancing procedures (underexcited operation) are permitted to have a maximum duration of 300 ms at the end of the fault.	True	Not applicable
7.7	For directly-coupled asynchronous generators: During the voltage rise, the power generating unit must behave in an underexcited manner.	True	Not applicable
7.8	For directly-coupled asynchronous generators: The speed of the PGU is maintained during and after the UVRT.	Speed deviates by $< 3\%$ of the synchronous speed from this. The slip is within a tolerance band of five times the design slip either side of the synchronous speed.	Not applicable
7.9	For directly-coupled asynchronous generators: The duration of the follow-up time after which the additional capacitors are switched out at the end of the UVRT can be set.	True	Not applicable
7.10	For PGU with directly-coupled asynchronous machine without converter in the cage circuit the following applies: The rise time of the	True	Not applicable

	active current after the end of the fault may be a maximum of 3 s.		
7.11	For PGU without double-fed asynchronous machine and without directly-coupled asynchronous machine without converter in the cage circuit, the following generally applies (also for multiple faults): The rise time of the active current after the end of the fault may be a maximum of 1 s.	True	Not applicable
7.12	Continuous dynamic grid support is used	Details provided	Compliant
<b>Limited dynamic grid support</b>			
4.1	All UVRT tests according to TG 3 have been fully completed with respect to the limited dynamic grid support.	True	Compliant
4.2	The PGU Type 2 can meet the requirements for limited dynamic grid support.	True or exception under Chapter 10.2.3.3.5	Compliant
4.3	The maximum apparent current of 10% $I_r$ is not exceeded after settling up to the end of the fault (for voltage drop between 45% $U_n$ and 60% $U_n$ )	True	Compliant
2.12	Full dynamic grid support is fulfilled according to the requirements above 0.7 $U_n$ (from 1 January 2021).	True	Not applicable
<b>Multiple faults</b>			
8.1	If the behaviour in the event of multiple faults has not been demonstrated by the manufacturer through calculations, alternatively the evidence may be provided through measurement: Test sequence or multiple faults to be ridden through according to Table 14 at $P \geq 75\%$ PrE without disconnecting from the grid.	True	Not applicable
8.2	Type 2 systems must be able to ride through any series of grid faults.	The evidence has been provided if the PGU is able to discharge the energy PE max for 2 s	Compliant
8.3	Based on a manufacturer's declaration it must be shown comprehensibly that the PGU is capable of riding through a multiple fault again after 30 minutes.	Details provided	Compliant
No.	Additional evidence	Acceptance criteria	
C	The reinforcing factor $k$ is adjustable between 2 and 6 in steps of 0.5 or smaller.	Manufacturer's declaration	Compliant
D	The fundamental ability to adjust the $k$ -factor must be proven through tests with different $k$ -factors ( $k=2$ and $k=4$ ). The have to be carried out in accordance with TG 3.	True or 2.5.	Compliant
<b>A.1.2.7.4.1 Contribution to short-circuit current</b>			
Requirement	Verification	Associated documents	Requirements

10.2.5.2	11.2.9	TR 3 DIN EN 60909-0 (VDE 0102)	Test report, manufacturer's declaration	Compliant
Remarks	Calculation of the short-circuit AC currents is done by the certification body and is identified in the PGU certificate.			
No.	Evaluation criteria		Acceptance criteria	
1	Short-circuit current after three-pole faults in accordance with 11.2.5 is stated as follows.		True	Compliant
1.1	At fault occurrence: As the highest instantaneous value (short-circuit current $I_p$ ) and as rms value of short-circuit current.		True	Compliant
1.2	The short-circuit current (1 period rms value) after a three-pole fault was shown with the times in Table 16.		True	Compliant
1.3	The instantaneous short-circuit current $i_p$ was identified and shown based on the measurement data according to DIN EN 60909-0 (VDE 0102).		True	Compliant
1.4	The starting short-circuit AC current $I_k$ has to be identified and shown according to DIN EN 60909-0 (VDE 0102).		True	Compliant
2	Disclosure of parameters required for calculation of the short-circuit AC in accordance with DIN EN 60909-0 took place		True	Compliant
No.	Additional evidence		Acceptance criteria	
A	All time plots of currents to be shown for three-pole faults are shown		True	Compliant
B	Manufacturer's specifications according to Table 15		Details provided	Compliant
A.1.2.8 Protection				
A.1.2.8.1.1. Reserve protection concept				
Not applicable				
A.1.2.8.2.1. Readability of protection settings				
Requirement	Verification	Associated documents	Requirements	
6.3.3	11.2.10	-	Manufacturer's declaration or component certificate	Not applicable
Remarks	-			
No.	Evaluation criteria		Acceptance criteria	
1	The protection devices on the power generating units have been designed in such a way that the settings can be easily read without additional equipment or if additional equipment is required, the authenticity and identification of the data read out is ensured.		True	Not applicable
A.1.2.8.3.1. Test terminal				
Requirement	Verification	Associated documents	Requirements	
6.3.3.5	11.2.10	-	Manufacturer's declaration	Not applicable
Remarks	Example of a test terminal in Chapter 6.3.3.5 Figure 3			
No.	Evaluation criteria		Acceptance criteria	

1	Protection test is possible without disconnecting wires.		True	Not applicable
1.1	The manufacturer's declaration includes a technical description of the test terminal demanded in requirement 1, as per Chapter 6.3.3.5 of the application rule.		True	Not applicable
<b>A.1.2.8.4.1. Operating range</b>				
Requirement	Verification	Associated documents	Requirements	
10.3.4.2.2 10.3.5.3.2	11.2.10	TG 3	Manufacturer's declaration, test report	Not applicable
Remarks	-			
No.	Evaluation criteria		Acceptance criteria	
1	A type test is available for the protection devices integrated in the PGU for the setting ranges required according to Table 11 or 13 according to FGW-TG3-Rev. 24 or later.		True	Not applicable
2	Additional protection devices which are present in the PGU are shown with their setting value range.		True	Not applicable
<b>A.1.2.8.5.1. Voltage protection device and Q(U) protection</b>				
Not applicable				
<b>A.1.2.8.6.1. Accuracy</b>				
Requirement	Verification	Associated documents	Requirements	
10.3.3.2 10.2.4.3	11.2.10	TG 3 FNN-Recommendation: Determination and Evaluation of the System Frequency - Effects of System-Side Interferences (Version 1.0)	Test procedure in accordance with TG 3	Not applicable
Remarks	-			
No.	Evaluation criteria		Acceptance criteria	
1	The required measurement accuracies for the protection devices of the PGU (voltage: $\pm 1\% U_n$ ; frequency: $\pm 0.1$ Hz; see FNN-Recommendation Annex B) are met. Regarding the frequency support equipment, TG 3 is currently being revised. Until the next revision from a measurement perspective an accuracy of 0.1 Hz must be demonstrated.		True	Not applicable
2	The reset ratio of the voltage protection devices is complied with.		$\geq 0.98$ (overvoltage protection) $\leq 1.02$ (undervoltage protection)	Not applicable
<b>A.1.2.8.7.1. Independence of the protection functions</b>				
Requirement	Verification	Associated documents	Requirements	
10.3.3.1	11.2.10	-	Manufacturer's declaration	Not applicable

Remarks	-			
No.	Evaluation criteria		Acceptance criteria	
1	The integrated protection in the PGU - if present - works independently of the control functions.		True	Not applicable
2	Function presentation to show that protection and control functions operate in different software blocks		Details provided	Not applicable
<b>A.1.2.8.8.1. Protection monitoring</b>				
Not applicable				
<b>A.1.2.8.9.1. Own and auxiliary power supply</b>				
Requirement	Verification	Associated documents	Requirements	
10.3.3.6	11.2.10	TG 3	Component certificate Manufacturer's declaration	Not applicable
Remarks	The utilisation of existing auxiliary power supplies is permissible if they also meet the requirements.			
No.	Evaluation criteria		Acceptance criteria	
1	Grid-independent auxiliary power supply is available and maintains protection functions for at least 5 s.		True	Not applicable
1a	Functionality of the protection functions within the operating ranges shown in Figure 4 proven.		True	Not applicable
2	A failure of the auxiliary power supply of the protection devices leads to immediate switch-off of the PGU		True	Not applicable
3	The protective functions are functional prior to the start of power input by the power generating unit.		True	Not applicable
No.	Additional evidence		Acceptance criteria	
A	A failure of the auxiliary power supply of the protection devices and/or system control leads to immediate triggering of the PGU's main switch.		True	Not applicable
<i>Remark: This evidence is optional.</i>				
<b>A.1.2.8.9.5. Fault logger</b>				
Not applicable				
<b>A.1.2.8.10.1. Coupling switch</b>				
Requirement	Verification	Associated documents	Requirements	
10.3 10.4.5	-	-	Manufacturer's declaration	Not applicable
Remarks	The evaluation criteria of Chapter A.1.2.8.10.1 only apply for PGU where the coupling switch falls within the scope of certification			
No.	Evaluation criteria		Acceptance criteria	
1	The coupling switch ensures three-pole galvanic separation		True	Not applicable
2	The coupling switch is designed as specified by the manufacturer. The switching capacity of the coupling switch is stated.		True	Not applicable
3	The coupling switch is able to be triggered without delay taking into		True	Not applicable

	account the protection equipment required according to 10.3			
4	The sum of time elements of the protection and switching equipment does not exceed 100 ms		True	Not applicable
A.1.2.9 Simulation models				
A.1.2.9.1.1 Requirements for simulation models				
Requirement	Verification	Associated documents	Requirements	
10.6	11.2.6	TG 4	Validated PGU models for the grid fault case and normal operation assume measurement results according to 11.2.4, 11.2.5, 11.2.7 and 11.2.10.	Not applicable
Remarks	-			
No.	Evaluation criteria		Acceptance criteria	
1	Functional scope of the models meets at least the requirements according to Chapter 11.2.6.2		True	Not applicable
1.1	If necessary, the named functions are mapped in multiple models		Allocation visible from model documentation.	Not applicable
2	Models for the grid fault case are implemented as rms value models. In special cases the use of EMT models is permitted.		True. To the extent that EMT models are used in justified cases, the calculation results are checked for robustness.	Not applicable
2.1	Models for the grid fault case map the positive and negative phase sequence systems and zero phase system		True. Asymmetric faults can be represented.	Not applicable
2.2	Models for the grid fault case can represent the behaviour in the event of a fault in the overarching grid and the return to quasi steady-state operation from any given quasi steady-state operating point.		True	Not applicable
2.3	Models for the grid fault case cover at least the PGU and protection devices, as long as these are part of the PGU		True	Not applicable
2.4	The time increment is a maximum of 10 ms. When using an automatic step width adjustment, the maximum step size is 0.2 s.		True	Not applicable
3	Models for normal operation represent all setting times and accuracies regarding active and reactive power according to the relevant requirements.		True	Not applicable
3.1	The difference from the rolling 5 s mean values for simulated and measured active and reactive power in normal operation remain under specified limits.		$ P1,mess - P1,sim  \leq \varepsilon \cdot SrE$ $ Q1,mess - Q1,sim  \leq \varepsilon \cdot SrE$ $ P2,mess - P2,sim  \leq \varepsilon \cdot SrE$	Not applicable

		$ Q2,mess - Q2,sim  \leq \varepsilon \cdot SrE$ $ P0,mess - P0,sim  \leq \varepsilon \cdot SrE$ $ Q0,mess - Q0,sim  \leq \varepsilon \cdot SrE$ With $\varepsilon = 0.15$ in the dynamic transition range and $\varepsilon = 0.05$ in the stationary range.	
3.2	For PGU models, which represent the behaviour for frequency deviations and which are used to determine the accuracy of aggregated PGS models, a comparison with measurements according to 11.2.7 has been completed.	True. Otherwise direct comparison of the aggregated model with the measurements according to 11.2.7.	Not applicable
4	PGU models are subjected to plausibility checks for use at additional operating points.	True	Not applicable
No.	Additional evidence	Acceptance criteria	
A	Validation of the PGU models for the grid fault case based on measurements according to 11.2.5 and 11.2.10 according to the specifications of TG 4 by a certification body accredited according to DIN EN ISO/IEC 17065 [10] has been completed.	True	Not applicable
B	Validation of the PGU models for normal operation based on measurements according to 11.2.4 and 11.2.7 according to the specifications of TG 4 by a certification body accredited according to DIN EN ISO/IEC 17065 [10] has been completed.	True	Not applicable
For Type 1 PGU the following applies:			
No.	Evaluation criteria	Acceptance criteria	
	The voltage controller and its model must not be changed for transfer to other PGU according to 11.2.1.	True	Not applicable
2	The model documentation covers all functionalities, interfaces and key setting values of the PGU model with permissible setting ranges.	True	Not applicable
2.1	Associated setting values in the PGU system control are documented.	True	Not applicable
2.2	Integration and application of the model in the simulation environment used are clearly described.	True	Not applicable
2.3	In the individual verification process, the validation of the PGU models is done based on TG 4. This validation is part of the extended declaration of conformity.	True	Not applicable
5	The requirements for transferability of simulation models from 11.2.5.3 are fulfilled.	True	Not applicable

## 4 PARAMETER LIST

**Table 1 – Access Levels**

Access Level	Group	Memory Type
1	Validation Testing	Flash
2	Certification	Flash
3	Integrator / Commissioning	Flash
4	Utility	EEPROM
5	End User	RAM

**Table 2 – Common Parameters**

Parameter	Description	Settings	Default
DERType	Nameplate DERTyp	0 to 5, 99	0
MaxWLim	Nominal max output power at controller or ECP	10.0 to 100.0	30
MaxVArLim	Nominal max output reactive power at controller or ECP	10.0 to 100.0	30
WMax	Setting for maximum active power and reference value for functions	10.0 to 100.0	30
VArAval	Available vars	0.0 to 100.0	30
VArMax	Setpoint for maximum reactive power;	10.0 to 100.0	30
VRef	Reference voltage for functions using grid voltage as input	10 to 600	400
DERNum	Number of DER units connected to controller or number of units	0 to16	1
PrampMax	Power gradients at a maximum rate of x % P <sub>Amax</sub> (= W <sub>Max</sub> ) per second	0.0 to 1.0	0.0066
PrampMin	Power gradients at a minimum rate of x % P <sub>Amax</sub> (= W <sub>Max</sub> ) per second	0.0 to 1.0	0.0033
ReconnRmpUp_ModEna	Reconnection ramp enable	0 or 1	1

**Table 3 – Possible Value for DERType**

Value	Description
0	Not applicable / Unknown
1	Virtual or mixed DER
2	Reciprocating engine
3	Fuel cell
4	Photovoltaic system
5	Combined heat and power
99	Other

**Table 4 – Parameters for reactive power management**

Parameter	Description	Settings	Default
VDE_Ctrl_ModEna	Selects one of four modes 0. Disabled – enables fixed Q setpoint 1. Voltage limiting function 2. Q(U) curve 3. Displacement factor $\cos \phi$ 4. Q(P) curve	0, 1, 2, 3 or 4	0
VDE_Ctrl_QRef	Set-point reference active power. See explanations for reactive power with voltage limiting function	1 to 100	5
VDE_Ctrl_UQ0	Default voltage. See explanations for Q(U) characteristic curve	10 to 600	405
VDE_Ctrl_cos_phi	Target power factor. Positive values represent an inductive power factor.	-0.5 to 0.5	0.95

**Table 5 – Parameters for Voltage Fault Detection**

Parameter	Description	Settings	Default
VFDet_LVFitThr	Low voltage fault threshold for positive sequence voltage in p.u.	0 to Vmin	0.9
VFDet_LVRcyThr	Low voltage fault recovery threshold for positive sequence voltage in p.u. Must be greater than VFDet_LVFitThr	0 to Vmin	0.91
VFDet_HVFitThr	High voltage fault threshold for positive sequence voltage in p.u.	Vmax to 1.3	1.1
VFDet_HVRcyThr	High voltage fault recovery threshold for positive sequence voltage in p.u. Must be less than VFDet_HVFitThr	Vmax to 1.3	1.09
VFDet_VNegFitThr	Fault threshold for negative sequence voltage in p.u.	0 to Vmin	0.033
VFDet_VNegRcyThr	Fault recovery threshold for negative sequence voltage in p.u. Must be less than VFDet_VNegFitThr	0 to Vmin	0.03

**Table 6 – Parameters for low voltage ride-through, symmetric fault**

Parameter	Description	Settings	Default
LVRT_ModEna	Enables/ disables the function	0 or 1	1
VRT_RvrtTms	Timeout period in milli-seconds	0 to 60000	5000
SLVRT_NumPts	Number of points in the array	1 to 20	0
SLVRT_sP0_x	Point 0, voltage value	0 to Vmin	0
SLVRT_sP0_T	Point 0, time value	0.001 to 3600	0
[...]	[...]	[...]	[...]
SLVRT_sP19_T	Point 19, voltage value	0 to Vmin	0
SLVRT_sP19_x	Point 19, time value	0.001 to 3600	0

**Table 7 – Parameters for low-voltage ride-through, asymmetric fault**

Parameter	Description	Settings	Default
LVRT_ModEna	Enables/ disables the function	0 or 1	1
ALVRT_NumPts	Number of points in the array	1 to 20	0
ALVRT_sP0_x	Point 0, voltage value	0 to Vmin	0
ALVRT_sP0_T	Point 0, time value	0.001 to 3600	0
[...]	[...]	[...]	[...]
ALVRT_sP19_T	Point 19, voltage value	0 to Vmin	0
ALVRT_sP19_x	Point 19, time value	0.001 to 3600	0

**Table 8 – Parameters for high voltage ride through**

Parameter	Description	Settings	Default
HVRT_ModEna	Enables/disables the function	0 or 1	1
HVRT_RvrtTms	Timeout period in seconds (not implemented)	0 to 60	0
HVRT_NumPts	Number of points in the array	1 to 20	0
HVRT_sP0_x	Point 0, voltage value	Vmax to 1.3	0
HVRT_sP0_T	Point 0, time value	0.001 to 3600	0
[...]	[...]	[...]	[...]
HVRT_sP19_T	Point 19, voltage value	Vmax to 1.3	0
HVRT_sP19_x	Point 19, time value	0.001 to 3600	0

**Table 9 – Parameters for AC over-voltage protection**

Parameter	Description	Settings	Default
HVRTD_ModEna	Enables/disables the function	0 or 1	0
HVRTD_NumPts	Number of points in the array	1 to 20	0
HVRTD_sP0_x	Point 0, voltage value	Vmax to 1.3	0
HVRTD_sP0_T	Point 0, time value	0.001 to 3600	0
[...]	[...]	[...]	[...]
HVRTD_sP19_T	Point 19, voltage value	Vmax to 1.3	0
HVRTD_sP19_x	Point 19, time value	0.001 to 3600	0

**Table 10 – Parameters for AC under-voltage protection**

Parameter	Description	Settings	Default
LVRTD_ModEna	Enables/disables the function	0 or 1	0
LVRTD_NumPts	Number of points in the array	1 to 20	0
LVRTD_sP0_x	Point 0, voltage value	0 to 600	0
LVRTD_sP0_T	Point 0, time value	0.001 to 3600	0
[...]	[...]	[...]	[...]
LVRTD_sP19_T	Point 19, voltage value	0 to 600	0
LVRTD_sP19_x	Point 19, time value	0.001 to 3600	0

**Table 11 – Parameters for AC over-frequency protection**

Parameter	Description	Settings	Default
HFRTD_ModEna	Enables/disables the function	0 or 1	1
HFRTD_NumPts	Number of points in the array	1 to 20	0
HFRTD_sP0_x	Point 0, Frequency value	Fnom to Fmax	0
HFRTD_sP0_T	Point 0, time value	0.001 to 3600	0
[...]	[...]	[...]	[...]
HFRTD_sP19_T	Point 19, Frequency value	Fnom to Fmax	0
HFRTD_sP19_x	Point 19, time value	0.001 to 3600	0

**Table 12 – Parameters for AC under-frequency protection**

Parameter	Description	Settings	Default
LFRTD_ModEna	Enables/disables the function	0 or 1	1
LFRTD_NumPts	Number of points in the array	1 to 20	0
LFRTD_sP0_x	Point 0, Frequency value	Fmin to Fnom	0
LFRTD_sP0_T	Point 0, time value	0.001 to 3600	0
[...]	[...]	[...]	[...]
LFRTD_sP19_T	Point 19, Frequency value	Fmin to Fnom	0
LFRTD_sP19_x	Point 19, time value	0.001 to 3600	0

Anti-islanding is enabled/disabled by flag iAI\_ModEna as below:

Parameter	Description	Settings	Default
iAI_ModEna	Enables/ disables Anti Islanding	0 or 1	1

**Table 13 – INV3 Parameters**

Parameter	Description	Settings	Default
INV3_OpModConPF	Enable the power factor function	0 or 1	0
INV3_OutPFSet	Setpoint for maintaining fixed power factor	0.5 to 1	0.93
INV3_PFsign	1 = IEC; 2 = EEI;	1 or 2	2
INV3_PFExt	Underexcited = 1; Overexcited = 0	0 or 1	1

**Table 14 – Parameters for INV4**

Parameter	Description	Settings	Default
INV4_OpModExIm	Enable set charge/discharge rate	0 or 1	1
INV4_OutWRte	Setpoint for charge/discharge as fraction of WMax. Allowed range is -1.0 to +1.0. Positive values indicated discharge into the grid.	-1.0 to 1.0	0

**Table 15 – FW21 Parameters**

Parameter	Description	Settings	Default
FW21_WCtlHzEna	Activation of the Active Power Reduction by Frequency function	0 or 1	0
FW21_HysEna	1 = Use of hysteresis	0 or 1	1
FW21_WGra	Active power gradient in percent of frozen active power value per Hz	0 to 1.0	1
FW21_HzStop	Delta frequency between stop frequency and nominal grid frequency	0.0 to 5.0	0.1
FW21_HzStr	Delta frequency between start frequency and nominal grid frequency	0.0 to 5.0	0.2
FW21_HzStopWGra	The maximum time-based rate of change at which power output returns to normal after having been capped by an over frequency event.	0.0 to 1.0	0.1
FW21_SnptW	Snapshot of power: 0 Off, the snapshot is not active (read only)	0 or 1	0
FW21_Pm	actual active power, capped at its current output level (read only)	0.0 to 100.0	-

**Table 16 – FW22 Parameters**

Parameter	Description	Settings	Default
FW22_ModEna	Enabled/disables the function	0, 1 or 2	2
FW22_DeptRef	Enumeration of the independent reference parameter units using SI units 0. Not applicable / unknown 1. None, dimensionless 2. VArS as percent of maximum vars (VArMax) 3. VArS as percent of available vars (VArAval) 4. VArS as percent of maximum (WMax) 5. Watts a percent of maximum watts (WMax) 6. Watts as percent of frozen active power WRef	0 to 7,99	2
FW22_RmpDecTmm	The maximum rate at which the dependent value (output) may be reduced in response to changes in the independent value (input). This is represented in terms of % of Reference value (e.g. VArMax) per minute.	0 to 10.0	0.1
FW22_RmpIncTmm	The maximum rate at which the dependent value (output) may be increased in response to changes in the independent value (input). This is represented in terms of % of Reference value per minute.	0 to 10.0	0.1
FW22_RmpRsUp	The maximum rate at which the dependent value (output) may be increased after releasing the frozen value of snap shot function. This is represented in terms of % of Reference value (e.g. WMax) per minute (not implemented).	0 to 10.0	0
FW22_WinTms	Time window (in seconds) within which to randomly execute a command (not implemented)	0 to 3600	0
FW22_RvrtTms	Timeout period (in seconds), after which the device will revert to its default status (not implemented)	0 to 86400	0
FW22_RmpTms	Ramp time, in seconds, for moving from current operational mode settings to new operational mode settings (not implemented)	0 to 3600	0
FW22_PairArray_NumPts	Number of points in the point array	1 to 20	8
FW22_PairArray_P0_xVal	Point 0, x value	-5.0 to 5.0	-0.05
FW22_PairArray_P0_yVal	Point 0, y value	0.001 to 3600	2
[...]	[...]	[...]	[...]
FW22_PairArray_P19_xVal	Point 19, x value	-5.0 to 5.0	0
FW22_PairArray_P19_yVal	Point 19, y value	0.001 to 3600	0

**Table 17 – WP41 Parameters**

Parameter	Description	Settings	Default
WP41_PFCtWEna	Activation of WP41	0 or 1	0
WP41_WStr	Power of start point	-1.0 to 1.0	0.2
WP41_WStop	Power of stop point	-1.0 to 1.0	0.4
WP41_PFStr	Power factor of start point	0.5 to 1	0.9
WP41_PFStop	Power factor of stop point	0.5 to 1	0.85
WP41_PFExtStr	Excitation of start point (1 = Underexcited, 0 = overexcited)	0 or 1	0
WP41_PFExtStop	Excitation of stop point (1 = Underexcited, 0 = overexcited)	0 or 1	1

**Table 18 – TV31 Parameters. At a minimum the ones red has to be defined**

Parameter	Description	Settings	Default
TV31_ModEna	Activation of dynamic reactive current support function	0 or 1	1
TV31_RLDNS	restricted limited dynamic network stability enable/disable 1. Limited dynamic network response (LDNS) enabled 2. Restricted dynamic network response (RDNS) enabled 3. Both enabled	0, 1, 2 or 3	0
TV31_ArGraMod	Mode of reactive current characteristic: selects between that edges, and where the gradients trend toward zero at the center 0 Disabled 1 Gradients trend toward zero at the dead band 2 Gradient trend toward zero at the center	0, 1 or 2	2
TV31_ArGraSag	Gradient for reactive current during a voltage sag (0 gradient implies no reactive current feed-in)	0.0 to 10.0	2
TV31_ArGraSwell	Gradient for reactive current during a voltage swell (0 gradient implies no reactive current feed-in)	0.0 to 10.0	2
TV31_FilTms	Filter time window for calculating moving average voltage. The maximum is 120 seconds	0 to 120	60
TV31_HoldTmms	Hold time (in milliseconds)	0 to 60	0
TV31_DelTmms	Delay time prior to current injection (in milliseconds)	0.0 to 100.0	15
TV31_DbVMin	Lower limit, voltage dead band	0.0 to 1.0	0.1
TV31_DbVMax	Upper limit, voltage dead band	0.0 to 1.0	0.1
TV31_BlzZnTmms	Block zone time (in milliseconds)	0.0 to 10000.0	5000
TV31_BlzZnV	Block zone voltage	0.0 to 600.0	0
TV31_HysBlzZnV	Hysteresis voltage	0.0 to 100.0	0
TV31_LvrtSt	When 1, low voltage ride-through incident is occurring (read only)	-	-

**Table 19 – RoCoF Parameters**

Parameter	Description	Settings	Default
RoCoF_ModEna	Enable rate of change of frequency protection method	0 or 1	1
RoCoF_trip_Freq_rate	Threshold rate of change of frequency Hz/s	0.1 to 5.0	2.5
RoCoF_trip_delay_time	Delay time from detection to tripping	0.0 to 600.0	0.08
RoCoF_Number_of_cycles	Adjustable number of cycles in order to calculate the rate of change of frequency using voltage zero crossings	4 to 50	10
RoCoF_error_time	Switch-on conditions evaluated as part of auto reconnection only after the set error time		1

## 5 TEST REPORT

<b>Extract from the test reports: 20618-1-TR</b> <b>Part 1: Power quality</b> <b>Determination of electrical properties of the PQstorl Series</b> <b>Extract No: 20618-1-Extract-TR</b> <b>Technische Richtlinie Tel 3 "Rev./Version 25, FGW"</b>	
Installation type:	Manufacturer's specifications
Manufacturer:	Generic type of installation:
	Tested model: See details below
	Rated power $P_n$ : See details below Rated apparent power $S_n$ : See details below
Test reports: 20618-1-TR	Period of measurement:

### 5.1 TEST RESULTS

#### 5.1.1 Rated data (tested units)

Nominal apparent power $S_n$	30 kW	Nominal current $I_n$	43 A
Nominal frequency $f_n$	50 Hz	Line voltage $U_n$	400 V

5.1.2 **Power quality (switching operations, harmonics, interharmonics, higher frequency components, flickers)**

**Power peaks**

$P_{600} = P_{10min}[kW]$	135,03	$P_{60} = P_{1min}[kW]$	135,87	$P_{0,2} = P_{momentan} [kW]$	135,87
$P_{600} = P_{600}/PnG$	0,988	$P_{60} = P_{60}/PnG$	0,988	$P_{0,2} = P_{0,2}/PnG$	0,989

**Switching operations**

Switching operation	Switch-on Pavailable < 10% Pn			
Grid impedance phase angle, $\psi_k$ [°]	30	50	70	85
Flicker form factor, $k_f(\psi_k)$	0,00	0,00	0,00	0,00
Voltage change factor, $k_u(\psi_k)$	0,00	0,00	0,00	0,00
Maximum switching current factor, $k_{i-max}$	0,00			

Switching operation	Switch-on at Pavailable = Pn			
Grid impedance phase angle, $\psi_k$ [°]	30	50	70	85
Flicker form factor, $k_f(\psi_k)$	0,00	0,00	0,00	0,00
Voltage change factor, $k_u(\psi_k)$	0,00	0,00	0,00	0,00
Maximum switching current factor, $k_{i-max}$	0,00			

Switching operation	Service shutdown at Pavailable = Pn			
Grid impedance phase angle, $\psi_k$ [°]	30	50	70	85
Flicker form factor, $k_f(\psi_k)$	0,04	0,04	0,04	0,04
Voltage change factor, $k_u(\psi_k)$	0,00	0,00	0,00	0,00
Maximum switching current factor, $k_{i-max}$	0,04			

**Harmonics Inverter:**

Pbin(%)	0	10	20	30	40	50	60	70	80	90	100	Max
Nr/Order	I <sub>h</sub> (%)	I <sub>h</sub> (%)	I <sub>h</sub> (%)	I <sub>h</sub> (%)	I <sub>h</sub> (%)	I <sub>h</sub> (%)	I <sub>h</sub> (%)	I <sub>h</sub> (%)	I <sub>h</sub> (%)	I <sub>h</sub> (%)	I <sub>h</sub> (%)	I <sub>h</sub> (%)
2	0,07	0,10	0,14	0,17	0,20	0,23	0,29	0,32	0,35	0,33	0,22	0,07
3	0,18	0,21	0,21	0,22	0,22	0,22	0,23	0,24	0,25	0,24	0,24	0,18
4	0,06	0,10	0,12	0,14	0,15	0,18	0,20	0,24	0,29	0,23	0,16	0,06
5	0,38	0,40	0,50	0,51	0,47	0,42	0,36	0,32	0,30	0,29	0,28	0,38
6	0,05	0,05	0,07	0,09	0,08	0,08	0,10	0,14	0,17	0,16	0,13	0,05
7	0,20	0,19	0,16	0,27	0,29	0,27	0,21	0,17	0,16	0,15	0,14	0,20
8	0,08	0,08	0,11	0,09	0,08	0,12	0,11	0,09	0,11	0,12	0,11	0,08
9	0,15	0,18	0,17	0,24	0,20	0,17	0,17	0,19	0,20	0,24	0,25	0,15
10	0,10	0,10	0,11	0,10	0,10	0,11	0,12	0,10	0,08	0,10	0,08	0,10
11	0,15	0,17	0,18	0,18	0,18	0,19	0,21	0,22	0,21	0,22	0,22	0,15
12	0,04	0,04	0,06	0,09	0,08	0,08	0,10	0,09	0,08	0,07	0,08	0,04
13	0,11	0,13	0,14	0,13	0,13	0,13	0,11	0,12	0,12	0,11	0,11	0,11
14	0,06	0,07	0,07	0,08	0,09	0,07	0,08	0,10	0,08	0,09	0,07	0,06
15	0,10	0,11	0,14	0,10	0,10	0,12	0,14	0,12	0,11	0,13	0,13	0,10
16	0,05	0,05	0,05	0,06	0,06	0,06	0,06	0,07	0,07	0,07	0,06	0,05
17	0,08	0,09	0,12	0,10	0,10	0,13	0,13	0,13	0,11	0,12	0,11	0,08
18	0,04	0,04	0,05	0,05	0,05	0,06	0,06	0,05	0,06	0,06	0,05	0,04
19	0,08	0,08	0,08	0,07	0,08	0,08	0,08	0,07	0,08	0,07	0,07	0,08
20	0,05	0,05	0,05	0,05	0,05	0,06	0,06	0,05	0,06	0,06	0,06	0,05
21	0,04	0,04	0,05	0,05	0,06	0,06	0,06	0,06	0,06	0,06	0,06	0,04
22	0,04	0,04	0,05	0,05	0,05	0,06	0,06	0,05	0,06	0,06	0,05	0,04
23	0,05	0,05	0,06	0,07	0,07	0,06	0,07	0,07	0,06	0,08	0,06	0,05
24	0,03	0,04	0,04	0,04	0,05	0,05	0,05	0,06	0,05	0,06	0,05	0,03
25	0,25	0,23	0,38	0,31	0,37	0,06	0,12	0,26	0,16	0,10	0,12	0,25
26	0,04	0,05	0,04	0,05	0,05	0,05	0,05	0,06	0,05	0,05	0,05	0,04
27	0,03	0,04	0,04	0,05	0,05	0,05	0,05	0,05	0,05	0,06	0,06	0,03
28	0,03	0,04	0,04	0,04	0,05	0,05	0,06	0,06	0,06	0,06	0,06	0,03
29	0,21	0,21	0,16	0,13	0,29	0,21	0,10	0,12	0,18	0,12	0,09	0,21
30	0,03	0,03	0,04	0,04	0,05	0,05	0,05	0,05	0,05	0,06	0,05	0,03
31	0,19	0,20	0,15	0,17	0,13	0,27	0,13	0,08	0,17	0,14	0,10	0,19
32	0,04	0,05	0,05	0,05	0,05	0,06	0,05	0,06	0,05	0,06	0,06	0,04
33	0,03	0,04	0,04	0,05	0,05	0,05	0,05	0,05	0,05	0,06	0,05	0,03
34	0,04	0,04	0,04	0,04	0,05	0,05	0,05	0,06	0,06	0,06	0,06	0,04
35	0,17	0,17	0,22	0,24	0,10	0,18	0,16	0,06	0,15	0,12	0,07	0,17
36	0,03	0,04	0,04	0,04	0,04	0,05	0,05	0,05	0,05	0,05	0,06	0,03
37	0,16	0,16	0,12	0,17	0,19	0,12	0,17	0,11	0,14	0,14	0,09	0,16
38	0,04	0,04	0,05	0,05	0,05	0,05	0,06	0,06	0,05	0,06	0,06	0,04
39	0,04	0,04	0,04	0,04	0,05	0,06	0,05	0,06	0,05	0,05	0,06	0,04
40	0,04	0,04	0,04	0,04	0,05	0,05	0,06	0,05	0,05	0,05	0,07	0,04
41	0,13	0,13	0,17	0,11	0,22	0,08	0,12	0,15	0,10	0,11	0,09	0,13
42	0,03	0,03	0,04	0,04	0,05	0,05	0,05	0,05	0,05	0,05	0,05	0,03
43	0,12	0,13	0,18	0,16	0,14	0,10	0,11	0,18	0,11	0,10	0,09	0,12
44	0,04	0,04	0,04	0,05	0,05	0,05	0,05	0,06	0,06	0,06	0,06	0,04
45	0,03	0,04	0,04	0,04	0,05	0,05	0,05	0,05	0,05	0,05	0,05	0,03
46	0,04	0,04	0,05	0,04	0,05	0,06	0,05	0,06	0,06	0,06	0,06	0,04
47	0,09	0,10	0,08	0,11	0,11	0,16	0,13	0,17	0,11	0,08	0,11	0,09
48	0,03	0,04	0,04	0,04	0,04	0,05	0,05	0,05	0,05	0,05	0,05	0,03
49	0,08	0,09	0,10	0,09	0,10	0,15	0,13	0,12	0,09	0,06	0,10	0,08
50	0,04	0,04	0,04	0,04	0,05	0,05	0,05	0,05	0,06	0,06	0,05	0,04
TDC (%)	0,75	0,78	0,90	0,94	0,95	0,88	0,83	0,84	0,87	0,83	0,73	0,75

**Harmonics Storage:**

Pbin(%)	0	10	20	30	40	50	60	70	80	90	100	Max
Nr/Order	I <sub>h</sub> (%)	I <sub>h</sub> (%)	I <sub>h</sub> (%)	I <sub>h</sub> (%)	I <sub>h</sub> (%)	I <sub>h</sub> (%)	I <sub>h</sub> (%)	I <sub>h</sub> (%)	I <sub>h</sub> (%)	I <sub>h</sub> (%)	I <sub>h</sub> (%)	I <sub>h</sub> (%)
2	0,07	0,06	0,08	0,09	0,09	0,10	0,13	0,18	0,16	0,10	0,09	0,18
3	0,18	0,16	0,21	0,22	0,21	0,21	0,21	0,22	0,22	0,21	0,21	0,22
4	0,06	0,06	0,08	0,07	0,09	0,08	0,15	0,23	0,18	0,11	0,12	0,23
5	0,38	0,42	0,43	0,44	0,49	0,52	0,57	0,59	0,61	0,65	0,68	0,68
6	0,05	0,05	0,06	0,07	0,07	0,07	0,11	0,16	0,19	0,10	0,10	0,19
7	0,20	0,25	0,33	0,31	0,32	0,35	0,38	0,43	0,46	0,46	0,47	0,47
8	0,08	0,08	0,10	0,14	0,14	0,10	0,11	0,20	0,22	0,11	0,11	0,22
9	0,15	0,14	0,23	0,15	0,16	0,16	0,21	0,31	0,31	0,28	0,26	0,31
10	0,10	0,09	0,11	0,12	0,14	0,12	0,15	0,22	0,18	0,10	0,11	0,22
11	0,15	0,14	0,18	0,16	0,16	0,18	0,20	0,21	0,18	0,18	0,20	0,21
12	0,04	0,04	0,05	0,06	0,06	0,07	0,09	0,13	0,15	0,08	0,07	0,15
13	0,11	0,11	0,14	0,16	0,19	0,16	0,14	0,14	0,14	0,16	0,17	0,19
14	0,06	0,06	0,10	0,08	0,08	0,09	0,10	0,14	0,12	0,07	0,07	0,14
15	0,10	0,09	0,13	0,12	0,12	0,12	0,14	0,12	0,12	0,14	0,17	0,17
16	0,05	0,05	0,05	0,06	0,05	0,06	0,06	0,11	0,10	0,08	0,06	0,11
17	0,08	0,07	0,09	0,09	0,09	0,08	0,08	0,08	0,09	0,09	0,08	0,09
18	0,04	0,04	0,04	0,05	0,05	0,05	0,05	0,07	0,07	0,05	0,05	0,07
19	0,08	0,08	0,09	0,10	0,08	0,09	0,09	0,09	0,08	0,08	0,09	0,10
20	0,05	0,05	0,07	0,06	0,07	0,06	0,06	0,08	0,08	0,07	0,06	0,08
21	0,04	0,04	0,05	0,05	0,05	0,05	0,05	0,07	0,07	0,06	0,06	0,07
22	0,04	0,05	0,05	0,06	0,06	0,06	0,06	0,07	0,07	0,06	0,06	0,07
23	0,05	0,04	0,06	0,06	0,06	0,05	0,05	0,06	0,05	0,05	0,05	0,06
24	0,03	0,03	0,04	0,04	0,05	0,04	0,05	0,06	0,06	0,05	0,05	0,06
25	0,25	0,26	0,22	0,18	0,38	0,19	0,23	0,26	0,24	0,14	0,17	0,38
26	0,04	0,04	0,06	0,05	0,06	0,05	0,05	0,06	0,06	0,06	0,05	0,06
27	0,03	0,03	0,04	0,04	0,05	0,05	0,04	0,05	0,06	0,05	0,05	0,06
28	0,03	0,04	0,05	0,05	0,05	0,05	0,05	0,06	0,06	0,06	0,06	0,06
29	0,21	0,22	0,26	0,29	0,24	0,28	0,18	0,18	0,20	0,14	0,16	0,29
30	0,03	0,03	0,04	0,05	0,05	0,04	0,04	0,05	0,06	0,05	0,05	0,06
31	0,19	0,21	0,25	0,25	0,15	0,24	0,13	0,08	0,15	0,10	0,12	0,25
32	0,04	0,04	0,05	0,05	0,05	0,05	0,05	0,06	0,07	0,06	0,06	0,07
33	0,03	0,03	0,04	0,05	0,05	0,04	0,04	0,06	0,07	0,05	0,05	0,07
34	0,04	0,04	0,04	0,05	0,05	0,05	0,04	0,07	0,06	0,06	0,06	0,07
35	0,17	0,17	0,13	0,10	0,13	0,15	0,12	0,08	0,09	0,13	0,12	0,17
36	0,03	0,03	0,04	0,05	0,05	0,05	0,04	0,06	0,07	0,05	0,05	0,07
37	0,16	0,17	0,21	0,15	0,20	0,15	0,13	0,12	0,11	0,13	0,13	0,21
38	0,04	0,04	0,05	0,05	0,05	0,05	0,04	0,07	0,06	0,06	0,06	0,07
39	0,04	0,03	0,04	0,05	0,05	0,05	0,04	0,05	0,06	0,05	0,05	0,06
40	0,04	0,04	0,05	0,05	0,04	0,04	0,04	0,07	0,06	0,06	0,06	0,07
41	0,04	0,04	0,05	0,05	0,04	0,04	0,04	0,07	0,06	0,06	0,06	0,07
42	0,04	0,04	0,05	0,05	0,04	0,04	0,04	0,07	0,06	0,06	0,06	0,07
43	0,04	0,04	0,05	0,05	0,04	0,04	0,04	0,07	0,06	0,06	0,06	0,07
44	0,04	0,04	0,05	0,05	0,04	0,04	0,04	0,07	0,06	0,06	0,06	0,07
45	0,04	0,04	0,05	0,05	0,04	0,04	0,04	0,07	0,06	0,06	0,06	0,07
46	0,04	0,04	0,05	0,05	0,04	0,04	0,04	0,07	0,06	0,06	0,06	0,07
47	0,04	0,04	0,05	0,05	0,04	0,04	0,04	0,07	0,06	0,06	0,06	0,07
48	0,04	0,04	0,05	0,05	0,04	0,04	0,04	0,07	0,06	0,06	0,06	0,07
49	0,04	0,04	0,05	0,05	0,04	0,04	0,04	0,07	0,06	0,06	0,06	0,07
50	0,04	0,04	0,05	0,05	0,04	0,04	0,04	0,07	0,06	0,06	0,06	0,07
TDC (%)	0,75	0,78	0,90	0,87	0,96	0,93	0,97	1,11	1,11	1,03	1,07	1,11

**Inter-harmonics Inverter**

F	0	10	20	30	40	50	60	70	80	90	100	Max
Nr/Order	Ih(%)	Ih(%)	Ih(%)	Ih(%)	Ih(%)	Ih(%)	Ih(%)	Ih(%)	Ih(%)	Ih(%)	Ih(%)	Ih(%)
75	0,04	0,21	0,34	0,54	0,73	0,86	1,07	1,28	1,62	1,70	1,88	1,88
125	0,03	0,04	0,15	0,13	0,34	0,44	0,40	0,42	0,72	0,65	0,69	0,72
175	0,03	0,04	0,15	0,14	0,26	0,22	0,32	0,37	0,33	0,39	0,53	0,53
225	0,10	0,06	0,05	0,12	0,09	0,18	0,23	0,26	0,27	0,41	0,34	0,41
275	0,08	0,06	0,11	0,16	0,15	0,14	0,31	0,24	0,23	0,21	0,28	0,31
325	0,05	0,01	0,09	0,10	0,10	0,08	0,24	0,20	0,25	0,29	0,27	0,29
375	0,06	0,03	0,07	0,08	0,10	0,03	0,18	0,14	0,23	0,23	0,32	0,32
425	0,06	0,03	0,08	0,09	0,09	0,06	0,08	0,13	0,15	0,24	0,22	0,24
475	0,02	0,07	0,11	0,15	0,14	0,13	0,06	0,11	0,20	0,16	0,07	0,20
525	0,07	0,06	0,05	0,09	0,11	0,09	0,05	0,07	0,19	0,12	0,17	0,19
575	0,05	0,06	0,08	0,11	0,05	0,07	0,09	0,17	0,20	0,13	0,19	0,20
625	0,03	0,03	0,07	0,08	0,06	0,12	0,10	0,11	0,18	0,14	0,13	0,18
675	0,05	0,05	0,07	0,03	0,05	0,03	0,08	0,12	0,19	0,08	0,13	0,19
725	0,06	0,04	0,07	0,05	0,04	0,06	0,07	0,07	0,13	0,14	0,07	0,14
775	0,02	0,06	0,07	0,04	0,09	0,09	0,04	0,12	0,15	0,10	0,12	0,15
825	0,02	0,03	0,05	0,03	0,06	0,05	0,04	0,09	0,15	0,12	0,06	0,15
875	0,04	0,04	0,04	0,03	0,06	0,07	0,09	0,06	0,16	0,06	0,09	0,16
925	0,02	0,03	0,03	0,02	0,01	0,05	0,05	0,06	0,15	0,11	0,09	0,15
975	0,05	0,03	0,03	0,04	0,04	0,06	0,07	0,06	0,15	0,09	0,07	0,15
1025	0,02	0,02	0,02	0,02	0,04	0,04	0,04	0,06	0,16	0,07	0,09	0,16
1075	0,02	0,03	0,03	0,04	0,01	0,05	0,04	0,06	0,15	0,05	0,07	0,15
1125	0,03	0,03	0,05	0,02	0,03	0,08	0,06	0,07	0,14	0,09	0,08	0,14
1175	0,02	0,03	0,04	0,05	0,05	0,03	0,06	0,08	0,13	0,06	0,09	0,13
1225	0,06	0,06	0,09	0,09	0,08	0,02	0,04	0,09	0,11	0,06	0,07	0,11
1275	0,13	0,12	0,19	0,16	0,22	0,04	0,10	0,13	0,22	0,04	0,11	0,22
1325	0,05	0,04	0,05	0,05	0,06	0,01	0,06	0,04	0,17	0,03	0,07	0,17
1375	0,05	0,04	0,05	0,03	0,06	0,02	0,05	0,02	0,17	0,05	0,08	0,17
1425	0,05	0,05	0,04	0,04	0,08	0,05	0,06	0,02	0,16	0,04	0,07	0,16
1475	0,16	0,13	0,10	0,08	0,19	0,15	0,07	0,11	0,15	0,10	0,07	0,19
1525	0,09	0,07	0,05	0,03	0,06	0,06	0,04	0,04	0,12	0,06	0,06	0,12
1575	0,13	0,13	0,10	0,12	0,10	0,24	0,09	0,07	0,23	0,09	0,08	0,24
1625	0,03	0,04	0,02	0,04	0,04	0,05	0,04	0,05	0,17	0,03	0,05	0,17
1675	0,04	0,03	0,03	0,04	0,05	0,05	0,03	0,03	0,16	0,03	0,06	0,16
1725	0,05	0,04	0,05	0,06	0,03	0,06	0,04	0,04	0,15	0,03	0,05	0,15
1775	0,12	0,12	0,17	0,19	0,09	0,13	0,14	0,06	0,15	0,13	0,06	0,19
1825	0,06	0,06	0,05	0,08	0,04	0,05	0,05	0,03	0,13	0,03	0,06	0,13
1875	0,12	0,13	0,10	0,15	0,18	0,08	0,16	0,08	0,24	0,14	0,07	0,24
1925	0,04	0,03	0,04	0,04	0,05	0,02	0,04	0,03	0,16	0,06	0,03	0,16
1975	0,03	0,02	0,02	0,03	0,04	0,04	0,06	0,05	0,16	0,06	0,05	0,16

**Inter-harmonics Storage**

F	0	10	20	30	40	50	60	70	80	90	100	Max
Nr/Order	lh(%)	lh(%)	lh(%)	lh(%)	lh(%)	lh(%)	lh(%)	lh(%)	lh(%)	lh(%)	lh(%)	lh(%)
75	0,04	0,24	0,41	0,62	0,76	0,94	1,09	1,42	1,55	1,75	1,93	1,93
125	0,03	0,09	0,17	0,24	0,31	0,35	0,47	0,51	0,60	0,58	0,78	0,78
175	0,03	0,07	0,13	0,14	0,22	0,16	0,40	0,26	0,40	0,48	0,49	0,49
225	0,10	0,08	0,11	0,16	0,15	0,24	0,31	0,36	0,25	0,25	0,44	0,44
275	0,08	0,04	0,07	0,08	0,19	0,17	0,34	0,26	0,25	0,21	0,29	0,34
325	0,05	0,02	0,09	0,09	0,12	0,10	0,35	0,15	0,19	0,32	0,21	0,35
375	0,06	0,05	0,02	0,09	0,14	0,13	0,36	0,06	0,20	0,23	0,23	0,36
425	0,06	0,07	0,04	0,06	0,03	0,13	0,41	0,20	0,16	0,25	0,23	0,41
475	0,02	0,07	0,04	0,08	0,10	0,17	0,41	0,15	0,26	0,13	0,11	0,41
525	0,07	0,04	0,08	0,09	0,05	0,14	0,35	0,12	0,16	0,15	0,06	0,35
575	0,05	0,09	0,09	0,08	0,11	0,06	0,31	0,12	0,10	0,21	0,21	0,31
625	0,03	0,04	0,07	0,05	0,05	0,06	0,26	0,06	0,09	0,14	0,10	0,26
675	0,05	0,06	0,02	0,04	0,08	0,09	0,30	0,09	0,11	0,09	0,13	0,30
725	0,06	0,06	0,03	0,02	0,07	0,04	0,26	0,10	0,11	0,14	0,13	0,26
775	0,02	0,01	0,06	0,05	0,07	0,04	0,33	0,05	0,10	0,09	0,05	0,33
825	0,02	0,02	0,04	0,01	0,06	0,03	0,25	0,11	0,11	0,12	0,11	0,25
875	0,04	0,03	0,07	0,05	0,04	0,04	0,31	0,07	0,07	0,14	0,12	0,31
925	0,02	0,03	0,04	0,07	0,06	0,04	0,28	0,11	0,07	0,09	0,09	0,28
975	0,05	0,04	0,03	0,04	0,04	0,03	0,21	0,06	0,07	0,09	0,07	0,21
1025	0,02	0,03	0,02	0,04	0,05	0,04	0,24	0,08	0,05	0,08	0,08	0,24
1075	0,02	0,02	0,02	0,01	0,05	0,04	0,25	0,06	0,05	0,07	0,09	0,25
1125	0,03	0,04	0,02	0,04	0,04	0,05	0,27	0,05	0,05	0,07	0,08	0,27
1175	0,02	0,04	0,06	0,04	0,06	0,05	0,27	0,04	0,05	0,04	0,08	0,27
1225	0,06	0,06	0,07	0,06	0,11	0,06	0,25	0,12	0,06	0,03	0,09	0,25
1275	0,13	0,13	0,13	0,09	0,22	0,13	0,38	0,13	0,17	0,12	0,08	0,38
1325	0,05	0,04	0,04	0,05	0,06	0,07	0,34	0,04	0,07	0,08	0,06	0,34
1375	0,05	0,04	0,03	0,04	0,05	0,07	0,29	0,02	0,07	0,07	0,05	0,29
1425	0,05	0,07	0,05	0,10	0,05	0,08	0,30	0,08	0,08	0,07	0,08	0,30
1475	0,16	0,13	0,17	0,19	0,15	0,20	0,41	0,11	0,18	0,08	0,11	0,41
1525	0,09	0,07	0,07	0,09	0,07	0,08	0,32	0,02	0,09	0,07	0,06	0,32
1575	0,13	0,14	0,18	0,19	0,09	0,15	0,33	0,04	0,12	0,07	0,12	0,33
1625	0,03	0,03	0,06	0,04	0,03	0,03	0,29	0,03	0,05	0,06	0,04	0,29
1675	0,04	0,03	0,04	0,02	0,04	0,03	0,29	0,06	0,07	0,04	0,03	0,29
1725	0,05	0,04	0,03	0,02	0,05	0,05	0,31	0,04	0,07	0,06	0,02	0,31
1775	0,12	0,14	0,11	0,05	0,08	0,10	0,36	0,07	0,03	0,11	0,13	0,36
1825	0,06	0,05	0,05	0,04	0,04	0,06	0,32	0,06	0,05	0,07	0,04	0,32
1875	0,12	0,15	0,17	0,12	0,18	0,13	0,23	0,08	0,09	0,11	0,15	0,23
1925	0,04	0,04	0,06	0,03	0,06	0,03	0,26	0,06	0,03	0,04	0,04	0,26
1975	0,03	0,02	0,03	0,02	0,04	0,01	0,30	0,05	0,02	0,03	0,04	0,30

**Higher frequency components Inverter**

F	0	10	20	30	40	50	60	70	80	90	100
kHz	lh(%)	lh(%)	lh(%)	lh(%)	lh(%)	lh(%)	lh(%)	lh(%)	lh(%)	lh(%)	lh(%)
2,1	0,04	0,04	0,05	0,04	0,06	0,04	0,06	0,07	0,14	0,07	0,02
2,3	0,02	0,02	0,03	0,03	0,02	0,04	0,04	0,06	0,16	0,06	0,04
2,5	0,02	0,02	0,03	0,02	0,05	0,03	0,02	0,02	0,15	0,06	0,03
2,7	0,01	0,01	0,03	0,03	0,02	0,03	0,01	0,03	0,12	0,03	0,04
2,9	0,01	0,01	0,02	0,02	0,01	0,02	0,03	0,01	0,13	0,03	0,02
3,1	0,00	0,00	0,02	0,02	0,02	0,02	0,01	0,02	0,13	0,03	0,03
3,3	0,00	0,00	0,02	0,01	0,02	0,01	0,01	0,02	0,12	0,02	0,02
3,5	0,00	0,00	0,01	0,01	0,01	0,01	0,02	0,02	0,12	0,01	0,02
3,7	0,01	0,01	0,01	0,02	0,01	0,01	0,01	0,02	0,12	0,03	0,03
3,9	0,00	0,00	0,02	0,02	0,01	0,02	0,01	0,02	0,13	0,02	0,03
4,1	0,00	0,00	0,01	0,01	0,01	0,02	0,01	0,02	0,11	0,03	0,03
4,3	0,01	0,00	0,01	0,01	0,01	0,02	0,02	0,04	0,12	0,03	0,01
4,5	0,01	0,00	0,01	0,01	0,02	0,03	0,02	0,03	0,08	0,02	0,02
4,7	0,00	0,00	0,01	0,01	0,02	0,02	0,01	0,01	0,11	0,02	0,01
4,9	0,01	0,00	0,02	0,02	0,03	0,04	0,04	0,03	0,12	0,04	0,02
5,1	0,01	0,01	0,02	0,03	0,05	0,03	0,05	0,03	0,06	0,03	0,04
5,3	0,01	0,00	0,01	0,01	0,01	0,01	0,01	0,03	0,09	0,02	0,01
5,5	0,02	0,01	0,01	0,05	0,01	0,04	0,04	0,03	0,08	0,04	0,05
5,7	0,02	0,01	0,02	0,03	0,07	0,05	0,05	0,02	0,12	0,04	0,04
5,9	0,01	0,01	0,02	0,03	0,02	0,04	0,04	0,02	0,07	0,02	0,03
6,1	0,02	0,02	0,02	0,07	0,06	0,05	0,09	0,08	0,09	0,03	0,05
6,3	0,02	0,03	0,06	0,03	0,07	0,06	0,12	0,11	0,12	0,03	0,03
6,5	0,03	0,01	0,06	0,07	0,04	0,05	0,05	0,08	0,11	0,06	0,03
6,7	0,05	0,06	0,12	0,09	0,33	0,30	0,32	0,18	0,10	0,19	0,07
6,9	0,03	0,02	0,05	0,04	0,05	0,08	0,10	0,10	0,10	0,09	0,05
7,1	0,02	0,00	0,02	0,01	0,03	0,01	0,03	0,01	0,08	0,01	0,03
7,3	0,01	0,01	0,02	0,03	0,06	0,04	0,06	0,03	0,07	0,04	0,03
7,5	0,01	0,01	0,01	0,03	0,05	0,04	0,05	0,01	0,03	0,04	0,03
7,7	0,01	0,00	0,01	0,02	0,01	0,03	0,02	0,02	0,04	0,02	0,03
7,9	0,01	0,01	0,01	0,01	0,02	0,04	0,01	0,01	0,04	0,04	0,05
8,1	0,01	0,01	0,01	0,02	0,02	0,02	0,03	0,02	0,02	0,02	0,04
8,3	0,01	0,01	0,00	0,01	0,01	0,02	0,02	0,01	0,03	0,02	0,02
8,5	0,01	0,01	0,01	0,01	0,01	0,01	0,03	0,01	0,02	0,02	0,02
8,7	0,02	0,01	0,01	0,02	0,01	0,02	0,02	0,01	0,03	0,01	0,02
8,9	0,01	0,01	0,01	0,00	0,01	0,01	0,02	0,02	0,03	0,01	0,02

**Higher frequency components Storage**

F	0	10	20	30	40	50	60	70	80	90	100
kHz	I <sub>h</sub> (%)	I <sub>h</sub> (%)	I <sub>h</sub> (%)	I <sub>h</sub> (%)	I <sub>h</sub> (%)	I <sub>h</sub> (%)	I <sub>h</sub> (%)	I <sub>h</sub> (%)	I <sub>h</sub> (%)	I <sub>h</sub> (%)	I <sub>h</sub> (%)
2,1	0,04	0,04	0,04	0,05	0,04	0,05	0,26	0,06	0,03	0,05	0,05
2,3	0,02	0,02	0,03	0,02	0,02	0,02	0,29	0,04	0,05	0,02	0,03
2,5	0,02	0,02	0,03	0,05	0,01	0,04	0,30	0,04	0,04	0,03	0,03
2,7	0,01	0,01	0,02	0,03	0,02	0,01	0,30	0,05	0,03	0,03	0,05
2,9	0,01	0,01	0,02	0,01	0,02	0,02	0,28	0,03	0,03	0,03	0,03
3,1	0,00	0,01	0,01	0,02	0,02	0,01	0,25	0,02	0,03	0,03	0,03
3,3	0,00	0,01	0,01	0,01	0,02	0,01	0,25	0,02	0,02	0,02	0,03
3,5	0,00	0,01	0,00	0,01	0,01	0,01	0,23	0,02	0,02	0,02	0,04
3,7	0,01	0,01	0,01	0,01	0,01	0,01	0,25	0,02	0,01	0,03	0,02
3,9	0,00	0,01	0,02	0,01	0,01	0,01	0,25	0,02	0,02	0,04	0,02
4,1	0,00	0,01	0,01	0,01	0,01	0,01	0,23	0,01	0,03	0,02	0,02
4,3	0,01	0,01	0,02	0,02	0,03	0,03	0,23	0,01	0,02	0,03	0,02
4,5	0,01	0,01	0,02	0,04	0,02	0,01	0,22	0,02	0,02	0,02	0,05
4,7	0,00	0,01	0,01	0,01	0,02	0,01	0,22	0,02	0,02	0,01	0,02
4,9	0,01	0,02	0,02	0,02	0,02	0,04	0,20	0,02	0,01	0,03	0,05
5,1	0,01	0,02	0,02	0,06	0,03	0,02	0,19	0,03	0,03	0,02	0,03
5,3	0,01	0,01	0,02	0,01	0,01	0,02	0,18	0,03	0,03	0,02	0,01
5,5	0,02	0,02	0,02	0,05	0,04	0,02	0,18	0,04	0,04	0,05	0,05
5,7	0,02	0,02	0,05	0,04	0,03	0,04	0,12	0,05	0,04	0,05	0,07
5,9	0,01	0,01	0,03	0,02	0,04	0,03	0,18	0,03	0,06	0,02	0,03
6,1	0,02	0,02	0,05	0,04	0,03	0,06	0,10	0,06	0,05	0,07	0,04
6,3	0,02	0,02	0,03	0,06	0,07	0,07	0,21	0,07	0,07	0,11	0,06
6,5	0,03	0,03	0,02	0,04	0,08	0,06	0,13	0,06	0,07	0,06	0,04
6,7	0,05	0,09	0,13	0,17	0,16	0,12	0,27	0,29	0,11	0,16	0,09
6,9	0,03	0,05	0,07	0,11	0,04	0,10	0,15	0,02	0,15	0,09	0,09
7,1	0,02	0,01	0,02	0,01	0,03	0,03	0,14	0,02	0,03	0,03	0,02
7,3	0,01	0,03	0,03	0,03	0,04	0,05	0,11	0,02	0,05	0,04	0,03
7,5	0,01	0,01	0,02	0,03	0,03	0,02	0,11	0,02	0,02	0,04	0,04
7,7	0,01	0,01	0,01	0,00	0,02	0,02	0,08	0,01	0,02	0,02	0,01
7,9	0,01	0,01	0,02	0,01	0,01	0,02	0,09	0,04	0,02	0,02	0,02
8,1	0,01	0,00	0,01	0,01	0,01	0,01	0,06	0,01	0,02	0,03	0,01
8,3	0,01	0,01	0,01	0,00	0,01	0,00	0,06	0,01	0,01	0,01	0,01
8,5	0,01	0,01	0,01	0,01	0,01	0,01	0,04	0,01	0,02	0,01	0,02
8,7	0,02	0,01	0,01	0,01	0,01	0,02	0,04	0,01	0,02	0,02	0,02
8,9	0,01	0,01	0,01	0,01	0,01	0,01	0,04	0,01	0,02	0,01	0,01

**Flickers**

Flicker coefficient  $c(\psi_k, P_{bin})$

P bin in %	0	10	20	30	40	50	60	70	80	≥90		
30°	0,00	0,00	0,00	0,00	0,00	0,00	0,00	0,00	0,00	0,00	0,00	0,00
50°	0,00	0,00	0,00	0,00	0,00	0,00	0,00	0,00	0,00	0,00	0,00	0,00
70°	0,00	0,00	0,00	0,00	0,00	0,00	0,00	0,00	0,00	0,00	0,00	0,00
85°	0,00	0,00	0,00	0,00	0,00	0,00	0,00	0,00	0,00	0,00	0,00	0,00

**Unsymmetrie**

P <sub>n</sub> in %	0	10	20	30	40	50	60	70	80	90	100	Max
U <sub>i</sub> in %	--	2,37%	0,88%	1,21%	1,00%	0,43%	0,37%	0,18%	0,32%	0,42%	0,21%	2,37%
P <sub>n</sub> in %	--	-10	-20	-30	-40	-50	-60	-70	-80	-90	-100	Max
U <sub>i</sub> in %	--	1,72%	0,99%	0,78%	0,15%	0,59%	0,61%	0,21%	0,58%	0,25%	0,22%	1,72%



5.1.3 **Active power vs frequency**

<b>Overfrequency</b>	<b>Mean power gradient at overfrequency</b>	Mean gradient 40 % Pn/Hz (Max 100% – Min 16,67%)	
	<b>Max. Setting time</b>	2 s	
	<b>Power gradient after recovery of overfrequency</b>	Max. gradient 10 % Pn/Hz (Max 100% – Min 5%)	
<b>Underfrequency</b>	<b>Mean power gradient at underfrequency</b>	Mean gradient 40 % Pn/Hz (Max 100% – Min 16,67%)	
	<b>Max. Setting time</b>	2 s	
	<b>Power gradient after recovery of underfrequency</b>	Max. gradient 10 % Pn/Hz (Max 100% – Min 5%)	
<b>The unit is able to run at reduced power</b>		<input checked="" type="checkbox"/> Yes	<input type="checkbox"/> No
<b>Max. deviation of power setting</b>		Exceeding 1,00 %	Undercut 1,83 %
<b>Disconnection from the grid at external active power setpoints at:</b>		Adjustable between 100%Pn and 0%Pn	
<b>Response time of the power output after a change in setpoint with minimal gradient</b>		P0->Pmin	0,01s 6%Pn/s
		Pmin ->P0	0,01s 6%Pn/s
<b>Response time of the power output after a change in setpoint with maximum gradient</b>		P0->Pmin	0,01s 3000%Pn/s
		Pmin ->P0	0,01s 3000%Pn/s

5.1.4 Provision of reactive power

Control of reactive power in normal operation mode and maximum reactive power range	<b>P/Pn</b>	<b>Q<sub>ind</sub> [kVAr]</b>	<b>Q<sub>cap</sub> [kVAr]</b>	<b>P/Pn</b>	<b>Q<sub>ind</sub> [kVAr]</b>	<b>Q<sub>cap</sub> [kVAr]</b>
	0%	-29,31	29,74	--	--	--
	10%	-29,16	29,78	-10%	-29,22	29,83
	20%	-28,81	29,81	-20%	-28,79	29,80
	30%	-28,01	29,40	-30%	-28,09	29,40
	40%	-26,92	28,15	-40%	-27,69	28,34
	50%	-25,47	26,80	-50%	-25,15	26,88
	60%	-23,67	24,88	-60%	-23,66	24,90
	70%	-21,20	22,30	-70%	-20,66	22,44
	80%	-17,56	19,00	-80%	-17,68	19,35
	90%	-13,75	14,08	-90%	-12,99	14,33
	100%	0,00	5,70	-100%	0,00	5,53
<b>Q<sub>ind</sub> and Q<sub>cap</sub> in kW and kVar</b>						
PQ diagrams/ working points of the voltage dependent PQ diagram	WP	U/Un in %		P in kW		Q in kVAr
	1 ind	0,90		-0,36		-26,51
	2 ind	1,10		-0,85		-28,98
	1 cap	0,90		-0,12		27,63
	2 cap	1,10		0,30		29,74
Control of reactive power through set point signal	☒ Power factor			☒ Reactive power		
	2,10% at 10%Pn			1,00 % max error		
Remark	Q (U) and Q (P) control have been tested, please see test report.					

### 5.1.5 Cut-in conditions

	Setting range [pu] or [Hz]	Cut in occurred within the given range
<b>Voltage</b>	0,90-1,10 (steps of 0,01 pu)	<input type="checkbox"/> No <input checked="" type="checkbox"/> Yes
<b>Frequency</b>	49,9-50,10 (steps of 0,10 Hz)	<input type="checkbox"/> No <input checked="" type="checkbox"/> Yes

Besides the internal interface protection, the internal interface switch can also be triggered by external interface protection.

### 5.1.6 Disconnection from the grid

Not applicable. The converter uses an external protection device

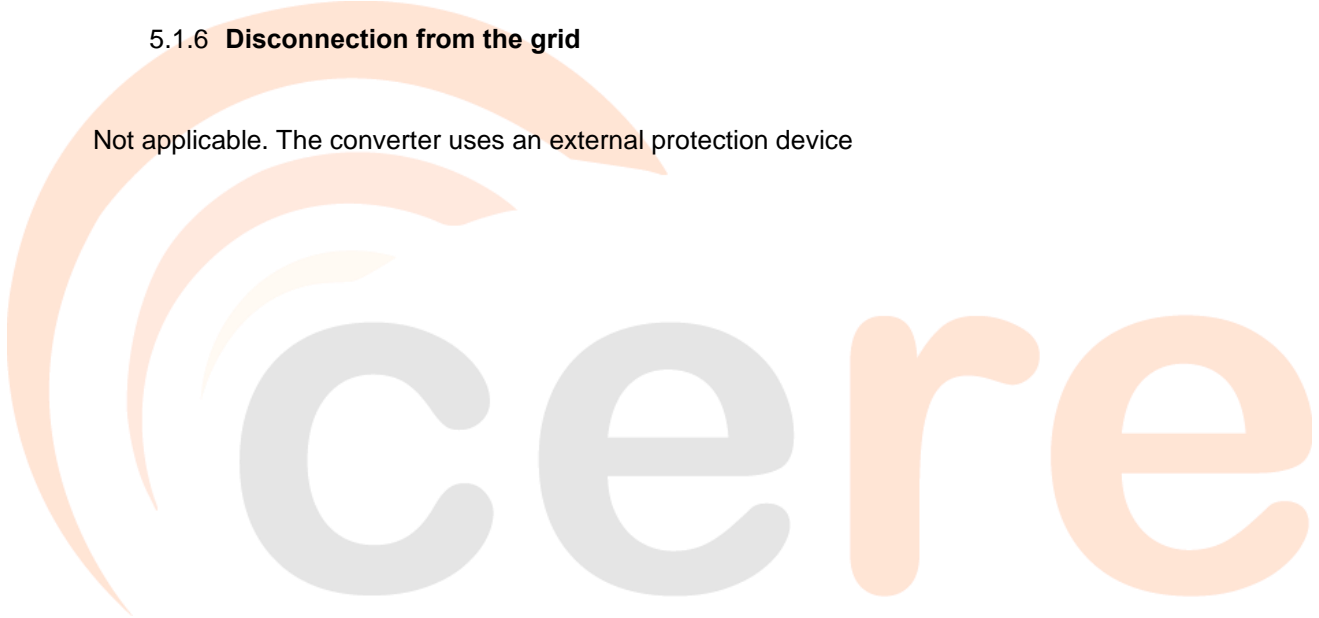

### 5.1.7 Operation field

Operation field for voltage and frequency is shown in the table below to give compliance with Clause 11.2.3 Quasi-static operation and phase swinging:

Test	Voltage Measured (%Un)	Frequency measured (Hz)	PF	Time Measured (s)	Disconnection (YES/NO)
1	110%	47,5 Hz	1,00	30 min	NO
2	90%	47,5 Hz	1,00	30 min	NO
3	90%	51,5 Hz	1,00	30 min	NO
4	110%	51,5 Hz	1,00	30 min	NO

NOTA: Time measured column shows the time measured. The measured points are in normal operation and it has been visually checked their continuous operation during more than 60 minutes.

### 5.1.8 P-Q and S-U Diagrams of the models

These diagrams shown below are provided by the manufacturer, as Clause 11.2.4 of VDE-AR-N requires the P-Q diagram for different voltages.

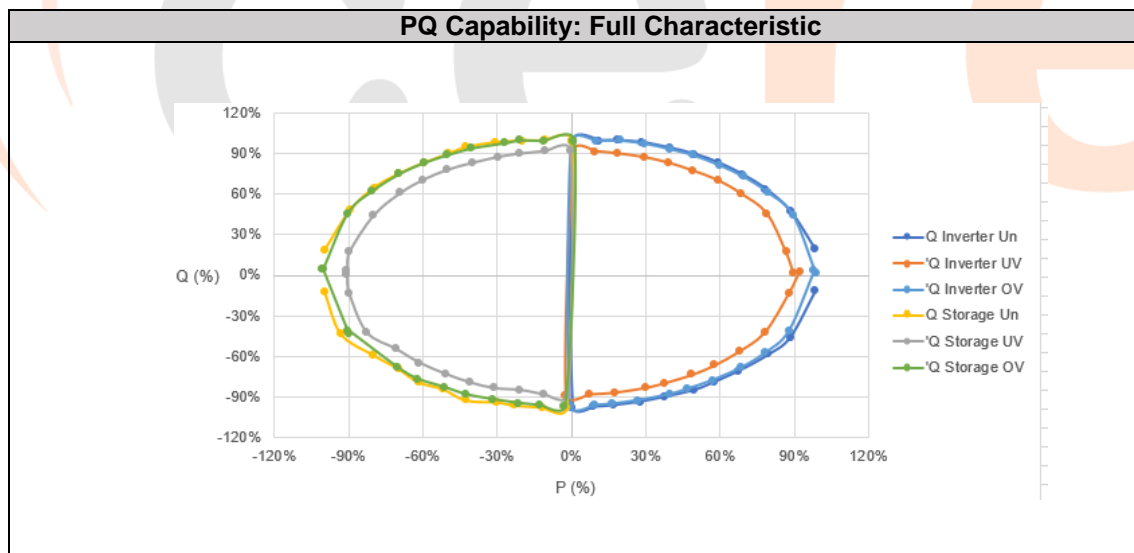

This extract from the test report summarizes the results of the test report No 20618-1-TR.